



DRUMS AND HARDWARE

2025 General Catalog

TAMA

TAMA DRUMS, HARDWARE, CONCERT PERCUSSION, MARCHING PERCUSSION & ACCESSORIES 2025 GENERAL CATALOG



Facebook tamadrums YouTube TAMAofficial Instagram officialtamadrums X @TAMAofficial

www.tama.com

Actual product colors may not exactly be the same as the one shown on the catalog photos due to lighting and photo resolution. All specifications are subject to change without notice.

©2025 TAMA DRUMS. All rights reserved.

TABLE OF CONTENTS

4-9	STAR Drums	53-54	Cymbal Stands
10-21	Starclassic	55-56	Tom Stands & Tom Holders
22-27	Superstar Classic	57-58	Hardware Kits
28-31	Imperialstar	59	Power Tower System
32	Stagestar	60-64	Clamps & Attachments
33-37	Club-JAM	64-66	Microphone Stands & Accessories
38	Cocktail-JAM	67-69	TAMA Percussion
39	True Touch Training Kit	69-71	Practice Tools
40-45	Snare Drums	72-80	Bags
46-48	Drum Pedals	80-94	Accessories
48-49	Hi-hat Stands	95-100	Sticks
50-51	Drum Thrones	101-109	Marching Percussion
52-53	Snare Stands	110-113	Concert Percussion



15
3
W31st
M20

TAMA STAR BUBINGA

Lacquer Finishes

STAR is the flagship line for TAMA drums. It takes the knowledge and research we cultivated for the Starclassic series to the next level, by reexamining every detail to enhance shell resonance. STAR Bubinga features a thin 5mm shell. Every shell comes equipped with 9mm thick Sound Focus Rings (SFR) for structural support. This shell configuration provides clear projection and resonance to highlight the distinct sound of Bubinga.



COLOR Pewter Blue Australian Acacia **PBA**

including:
 22"x16" bass drum
 8"x6" tom tom
 10"x7" tom tom
 12"x8" tom tom
 14"x12" floor tom
 16"x14" floor tom
 14"x6.5" snare drum

INDIVIDUAL MODEL NUMBERS

Diameter	Depth	Model No.
Bass Drums		
16"	12"	TBB1612S
18"	14"	TBB1814S
18"	15"	TBB1815S
18"	16"	TBB1816S
20"	14"	TBB2014S
20"	16"	TBB2016S
20"	17"	TBB2017S
20"	18"	TBB2018S
22"	14"	TBB2214S
22"	16"	TBB2216S
22"	17"	TBB2217S
22"	18"	TBB2218S
24"	14"	TBB2414S
24"	16"	TBB2416S
24"	17"	TBB2417S
24"	18"	TBB2418S
26"	14"	TBB2614S
26"	16"	TBB2616S
Floor Toms		
13"	12"	TBF1312S
14"	12"	TBF1412S
14"	13"	TBF1413S
14"	14"	TBF1414S
15"	13"	TBF1513S
15"	14"	TBF1514S
15"	15"	TBF1515S
16"	14"	TBF1614S
16"	15"	TBF1615S
16"	16"	TBF1616S
18"	14"	TBF1814S
18"	15"	TBF1815S
18"	16"	TBF1816S

Diameter	Depth	Model No.
Tom Toms		
8"	6"	TBT0806S
8"	7"	TBT0807S
8"	8"	TBT0808S
10"	6.5"	TBT1065S
10"	7"	TBT1007S
10"	8"	TBT1008S
10"	9"	TBT1009S
10"	10"	TBT1010S
12"	7"	TBT1207S
12"	8"	TBT1208S
12"	9"	TBT1209S
12"	10"	TBT1210S
12"	11"	TBT1211S
13"	7.5"	TBT1375S
13"	9"	TBT1309S
13"	10"	TBT1310S
13"	11"	TBT1311S
13"	12"	TBT1312S
14"	8"	TBT1408S
14"	10"	TBT1410S
14"	11"	TBT1411S
14"	12"	TBT1412S
14"	13"	TBT1413S
Snare Drums		
13"	6"	TBS136S
14"	5.5"	TBS1455S
14"	6.5"	TBS1465S
14"	8"	TBS148S

KIT CONFIGURATIONS LIST

[20" BD 3pc Shell Kit] **NEW**

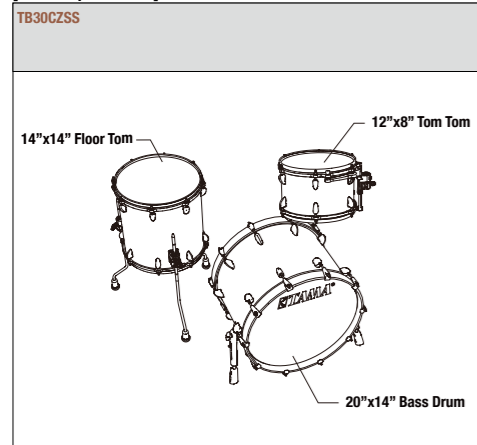

[22" BD 4pc Shell Kit] **NEW**

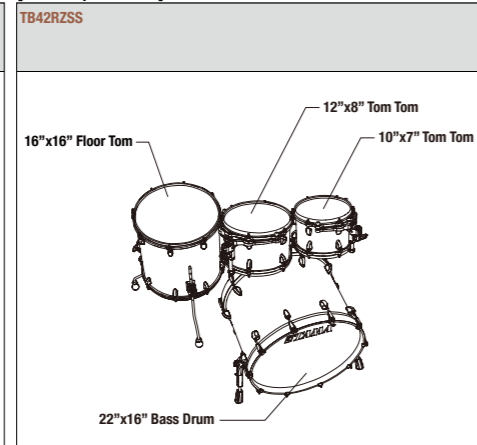

*only drums w/outside inlay and matched finish bass drum hoops.

SPECIFICATIONS

Shells
 5mm, 5ply Bubinga + 1 inner ply Cordia, or 5ply Bubinga + 1 outer ply Australian Acacia + 1 inner Ply Cordia for SAC/PBA, or 5ply Bubinga + 1 outer ply Indian Laurel + 1 inner ply Cordia for LNTI, or 4ply Bubinga + 1 outer & 1 inner ply Cordia for CDKG/CDKR, w/ 9mm Sound Focus Rings

- STAR Bearing Edges
- Super Resonant Mounting System
- Quick-Lock Tom Brackets
- Minimum Shell Contact
- STAR Floor Tom Legs
- Hold Tight™ Washers
- Remo® Drum Heads

MODEL NUMBER SYSTEM - Individual Drums

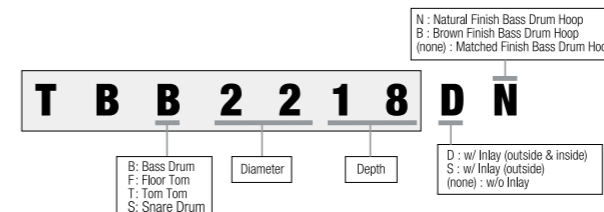

FINISHES (Lacquer)

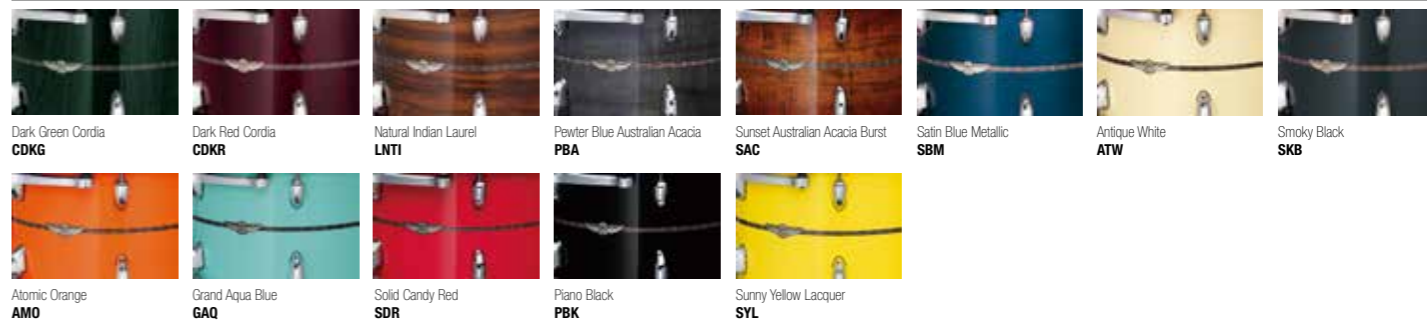

TAMA STAR MAPLE

Lacquer Finishes

STAR is the flagship line for TAMA drums. It takes the knowledge and research we cultivated for the Starclassic series to the next level, by reexamining every detail to enhance shell resonance. STAR Maple shell's "Solid Core Ply" is a totally new design for this series. This unique shell provides the warm, open tone of Maple, combined with the rich, hearty sound of a solid ply shell.



COLOR Emerald Sea Curly Maple Burst **RECB**

including:
 22"x16" bass drum
 8"x6" tom tom
 10"x7" tom tom
 12"x8" tom tom
 14"x14" floor tom
 16"x16" floor tom
 14"x6.5" snare drum

INDIVIDUAL MODEL NUMBERS

Diameter	Depth	Model No.		
Bass Drums				
16"	12"	TMB1612S		
18"	14"	TMB1814S		
18"	15"	TMB1815S		
18"	16"	TMB1816S		
20"	14"	TMB2014S		
20"	16"	TMB2016S		
20"	17"	TMB2017S		
20"	18"	TMB2018S		
22"	14"	TMB2214S		
22"	16"	TMB2216S		
22"	17"	TMB2217S		
22"	18"	TMB2218S		
24"	14"	TMB2414S		
24"	16"	TMB2416S		
24"	17"	TMB2417S		
24"	18"	TMB2418S		
26"	14"	TMB2614S		
26"	16"	TMB2616S		
Floor Toms				
13"	12"	TMF1312S		
14"	12"	TMF1412S		
14"	13"	TMF1413S		
14"	14"	TMF1414S		
15"	13"	TMF1513S		
15"	14"	TMF1514S		
15"	15"	TMF1515S		
16"	14"	TMF1614S		
16"	15"	TMF1615S		
16"	16"	TMF1616S		
18"	14"	TMF1814S		
18"	15"	TMF1815S		
18"	16"	TMF1816S		

Diameter	Depth	Model No.		
Tom Toms				
8"	6"	TMT0806S		
8"	7"	TMT0807S		
8"	8"	TMT0808S		
10"	6.5"	TMT1065S		
10"	7"	TMT1007S		
10"	8"	TMT1008S		
10"	9"	TMT1009S		
10"	10"	TMT1010S		
12"	7"	TMT1207S		
12"	8"	TMT1208S		
12"	9"	TMT1209S		
12"	10"	TMT1210S		
12"	11"	TMT1211S		
13"	7.5"	TMT1375S		
13"	9"	TMT1309S		
13"	10"	TMT1310S		
13"	11"	TMT1311S		
13"	12"	TMT1312S		
14"	8"	TMT1408S		
14"	10"	TMT1410S		
14"	11"	TMT1411S		
14"	12"	TMT1412S		
14"	13"	TMT1413S		
Snare Drums				
13"	6"	TMS136S		
14"	5.5"	TMS1455S		
14"	6.5"	TMS1465S		
14"	8"	TMS148S		

KIT CONFIGURATIONS LIST

[20" BD 3pc Shell Kit] **NEW**

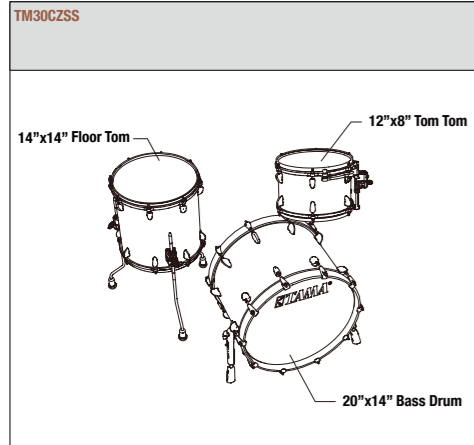

[22" BD 4pc Shell Kit] **NEW**

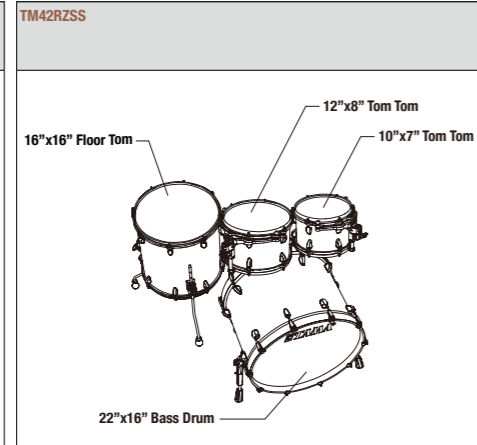

*only drums w/outside inlay and matched finish bass drum hoops.

MODEL NUMBER SYSTEM - Individual Drums

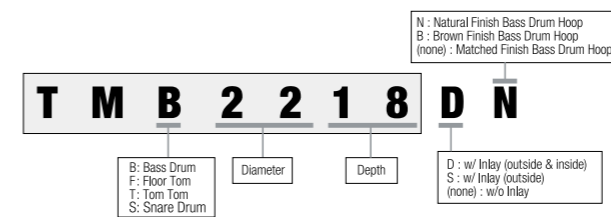

SPECIFICATIONS

Shells
 5mm, 5ply Maple or 5ply Maple +1 outer ply Curly Maple for RGCM/RECB/ROL/RCM
 w/ 5mm Sound Focus Rings

- STAR Bearing Edges
- Super Resonant Mounting System
- Quick-Lock Tom Brackets
- Minimum Shell Contact
- STAR Floor Tom Legs
- Hold Tight™ Washers
- Remo® Drum Heads

FINISHES (Lacquer)

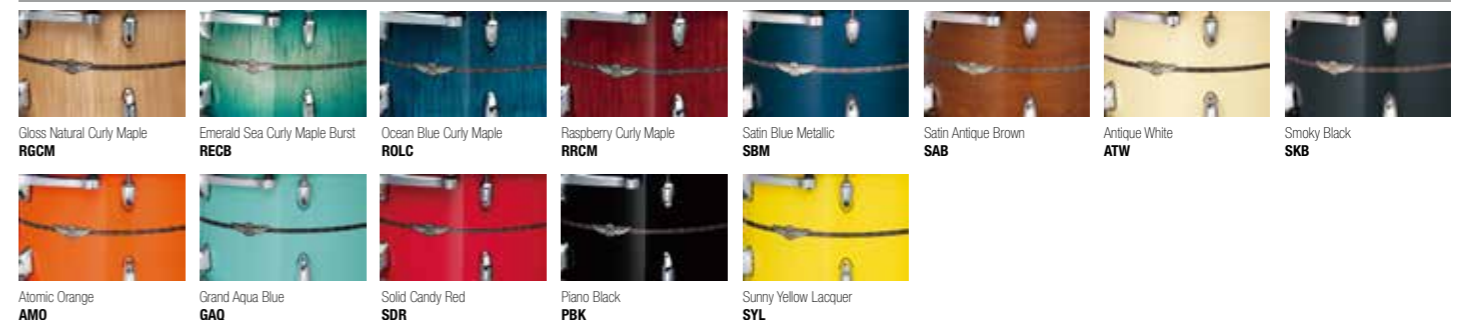

TAMA STAR WALNUT

Lacquer Finishes

STAR is the flagship line for TAMA drums. It takes the knowledge and research we cultivated for the Starclassic series to the next level, by reexamining every detail to enhance shell resonance. Walnut has long been favored by furniture makers for both its beauty and durability. As a drum shell material, Walnut's naturally EQ'ed tone has been praised by the drum community for both the stage and the studio. The STAR Walnut shells project booming low end with enough cut to be heard through any mix.



COLOR Antique White Japanese Chestnut AWC

TW42RZS basic kit

including:
22"x16" bass drum
10"x7" tom tom
12"x8" tom tom
16"x16" floor tom

[add-on]
14"x6.5" snare drum

KIT CONFIGURATIONS LIST

[20" BD 3pc Shell Kit] (HIN)

TW30CZS

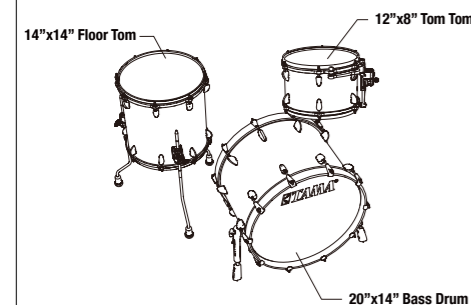

[22" BD 4pc Shell Kit]

TW42RZS

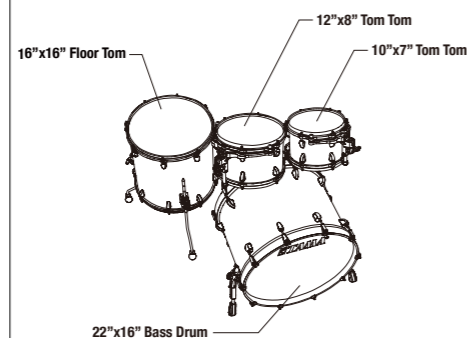

INDIVIDUAL MODEL NUMBERS

Diameter	Depth	Model No.		
Bass Drums				
16"	12"	TWB1612		
18"	14"	TWB1814		
18"	15"	TWB1815		
18"	16"	TWB1816		
20"	14"	TWB2014		
20"	16"	TWB2016		
20"	17"	TWB2017		
20"	18"	TWB2018		
22"	14"	TWB2214		
22"	16"	TWB2216		
22"	17"	TWB2217		
22"	18"	TWB2218		
24"	14"	TWB2414		
24"	16"	TWB2416		
24"	17"	TWB2417		
24"	18"	TWB2418		
26"	14"	TWB2614		
26"	16"	TWB2616		
Floor Toms				
13"	12"	TWF1312		
14"	12"	TWF1412		
14"	13"	TWF1413		
14"	14"	TWF1414		
15"	13"	TWF1513		
15"	14"	TWF1514		
15"	15"	TWF1515		
16"	14"	TWF1614		
16"	15"	TWF1615		
16"	16"	TWF1616		
18"	14"	TWF1814		
18"	15"	TWF1815		
18"	16"	TWF1816		

Diameter	Depth	Model No.		
Tom Toms				
8"	6"	TWT0806		
8"	7"	TWT0807		
8"	8"	TWT0808		
10"	6.5"	TWT1065		
10"	7"	TWT1007		
10"	8"	TWT1008		
10"	9"	TWT1009		
10"	10"	TWT1010		
12"	7"	TWT1207		
12"	8"	TWT1208		
12"	9"	TWT1209		
12"	10"	TWT1210		
12"	11"	TWT1211		
13"	7.5"	TWT1375		
13"	9"	TWT1309		
13"	10"	TWT1310		
13"	11"	TWT1311		
13"	12"	TWT1312		
14"	8"	TWT1408		
14"	10"	TWT1410		
14"	11"	TWT1411		
14"	12"	TWT1412		
14"	13"	TWT1413		
Snare Drums				
13"	6"	TWS136		
14"	5.5"	TWS1455		
14"	6.5"	TWS1465		
14"	8"	TWS148		

SPECIFICATIONS

Shells

All Walnut Shell TT/FT/SD: 6mm 6ply, BD: 7mm 7ply (except AJUB, AGJB, ASBJ, ASCS, LIC, AWC, RSC)
 *AJUB, AGJB, ASBJ, ASCS
 TT/FT/SD: 6mm, 4ply Walnut + 2 outer ply Japanese Sen
 BD: 7mm, 5ply Walnut + 2 outer ply Japanese Sen
 *LIC, AWC, RSC
 TT/FT/SD: 6mm, 5ply Walnut + 1 outer ply Japanese Chestnut
 BD: 7mm, 6ply Walnut + 1 outer ply Japanese Chestnut

STAR Bearing Edges
 Super Resonant Mounting System
 Quick-Lock Tom Brackets
 Minimum Shell Contact
 STAR Floor Tom Legs
 Remo® Drum Heads

MODEL NUMBER SYSTEM - Individual Drums

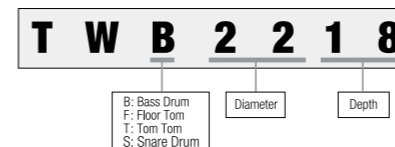

FINISHES (Lacquer)

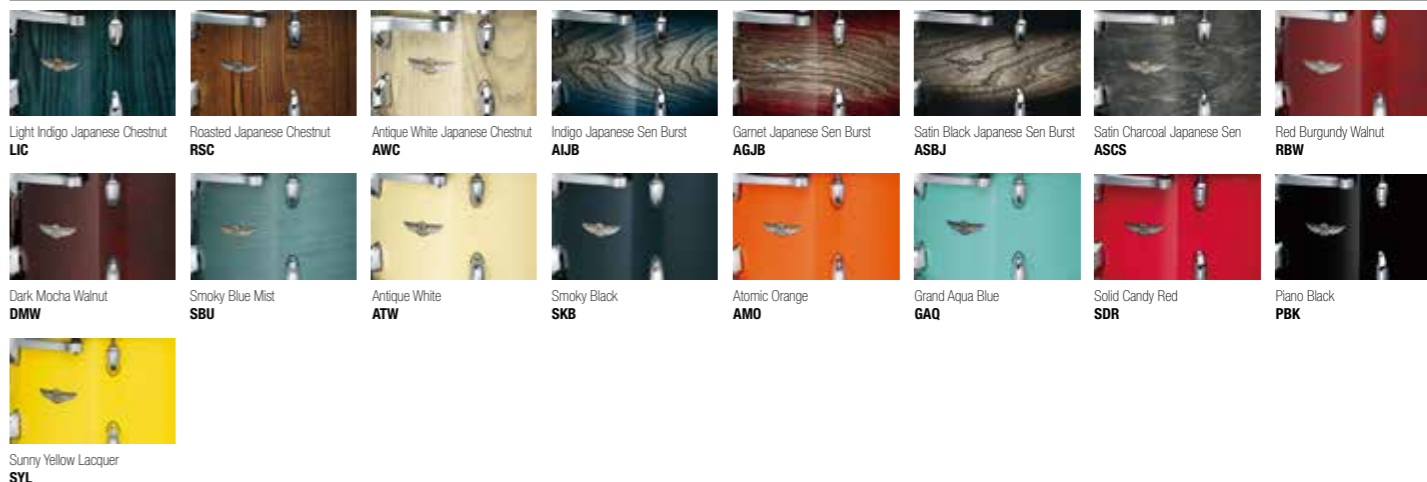

STARCLASSIC MAPLE

Exotic Finishes

In the '80s TAMA's Superstars and Imperialstars reigned supreme - the perfect drums for the times. But TAMA's builders and designers wanted something that transcended trends, something timeless - drums that understood a player's passion and allowed the expression of every genre, style, mood, and technique. They created Starclassic Maple drums...and ignited the thin-shell revolution. And now the Exotic Finish line offers beautiful, one-of-a-kind exotic wood exteriors for that extra luxurious touch.

Numerous options are available to meet the varied and critical needs of professional drummers including a selection of about 30 different shell sizes. Starclassic Maple also features three shell hardware finishes to choose from: Black Nickel, Chrome and Smoked Black Nickel. Starclassic Maple is simply an unprecedented combination of sight and sound.



COLOR Marine Shoreline Movingui Fade **VMMF**
w/ chrome hardware

ME42TZS basic kit

including:
22"x16" bass drum
10"x7" tom tom
12"x8" tom tom
16"x16" floor tom

[add-on]
14"x6.5" snare drum

KIT CONFIGURATIONS LIST

[22" BD 3pc Shell Kit]

ME32CZS w/ Chrome Hardware
ME32CZBS w/ Black Nickel Hardware
ME32CZUS w/ Smoked Black Nickel Hardware

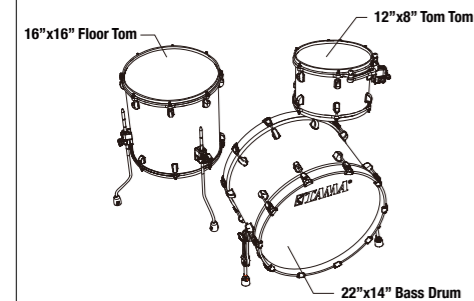

[22" BD 4pc Shell Kit]

ME42TZS w/ Chrome Hardware
ME42TZBS w/ Black Nickel Hardware
ME42TZUS w/ Smoked Black Nickel Hardware

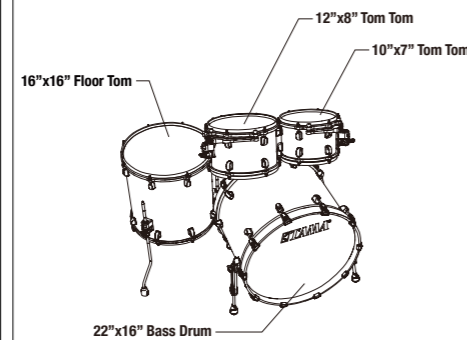

INDIVIDUAL MODEL NUMBERS

Diameter	Depth	Model No.		
		Black Nickel	Chrome	Smoked Black Nickel
Bass Drums *To order Bass Drum w/ Tom Holder Base, please substitute "Z" with "M". Ex MEB2218Z → MEB2218M				
16"	12"	MEB1612ZB	MEB1612Z	MEB1612ZU
18"	14"	MEB1814ZB	MEB1814Z	MEB1814ZU
20"	14"	MEB2014ZB	MEB2014Z	MEB2014ZU
20"	16"	MEB2016ZB	MEB2016Z	MEB2016ZU
22"	14"	MEB2214ZB	MEB2214Z	MEB2214ZU
22"	16"	MEB2216ZB	MEB2216Z	MEB2216ZU
22"	18"	MEB2218ZB	MEB2218Z	MEB2218ZU
24"	14"	MEB2414ZB	MEB2414Z	MEB2414ZU
24"	16"	MEB2416ZB	MEB2416Z	MEB2416ZU
Floor Toms				
13"	12"	MEF1312B	MEF1312	MEF1312U
14"	12"	MEF1412B	MEF1412	MEF1412U
14"	14"	MEF1414B	MEF1414	MEF1414U
16"	14"	MEF1614B	MEF1614	MEF1614U
16"	16"	MEF1616B	MEF1616	MEF1616U
18"	16"	MEF1816B	MEF1816	MEF1816U
Tom Toms				
8"	6"	MET0806B	MET0806	MET0806U
8"	7"	MET0807B	MET0807	MET0807U
10"	6.5"	MET1065B	MET1065	MET1065U
10"	7"	MET1007B	MET1007	MET1007U
10"	8"	MET1008B	MET1008	MET1008U
10"	9"	MET1009B	MET1009	MET1009U
12"	7"	MET1207B	MET1207	MET1207U
12"	8"	MET1208B	MET1208	MET1208U
12"	9"	MET1209B	MET1209	MET1209U
12"	10"	MET1210B	MET1210	MET1210U
13"	7.5"	MET1375B	MET1375	MET1375U
13"	9"	MET1309B	MET1309	MET1309U
13"	10"	MET1310B	MET1310	MET1310U
13"	11"	MET1311B	MET1311	MET1311U
14"	10"	MET1410B	MET1410	MET1410U
14"	11"	MET1411B	MET1411	MET1411U
14"	12"	MET1412B	MET1412	MET1412U
Snare Drums				
13"	6"	MES136B	MES136	MES136U
14"	5.5"	MES1455B	MES1455	MES1455U
14"	6.5"	MES1465B	MES1465	MES1465U
14"	8"	MES148B	MES148	MES148U

SPECIFICATIONS

Shells

(LEWB/LNWB/LRWB)
TT/FT: 5mm, 6ply Maple + 1 outer ply Pacific Walnut
BD/SD: 7mm, 8ply Maple + 1 outer ply Pacific Walnut

(VGLM/VTBV/VMMF)
TT/FT: 5mm, 6ply Maple + 1 outer ply Movingui
BD/SD: 7mm, 8ply Maple + 1 outer ply Movingui

Star-Cast Mounting System
Quick-Lock Tom Bracket
EVANS® Heads
Die-Cast Hoops
Hold Tight™ Washers
Claw Hooks w/ Rubber Spacers
Cushioned Floor Tom Legs

OPTION



MODEL NUMBER SYSTEM - Individual Drums

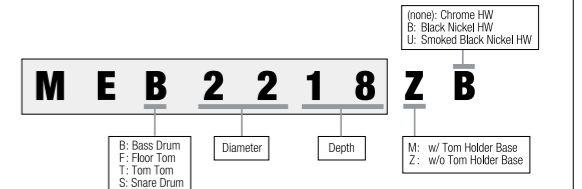

FINISHES (Lacquer)

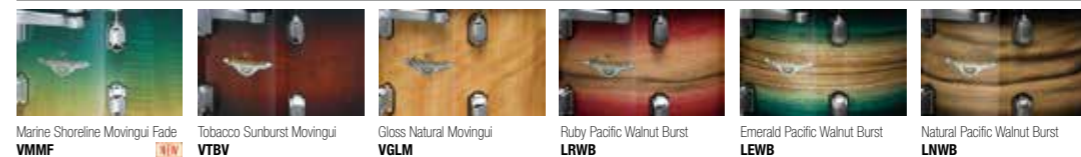

STARCLASSIC MAPLE

Lacquer Finishes



COLOR Molten Electric Blue Burst **MEB**
w/ black nickel hardware

MA42TZBNS basic kit

including:
22"x16" bass drum
10"x7" tom tom
12"x8" tom tom
16"x16" floor tom

[add-on]
14"x6.5" snare drum

KIT CONFIGURATIONS LIST

[22" BD 3pc Shell Kit]

MA32CZS w/ Chrome Hardware
MA32CZBNS w/ Black Nickel Hardware
MA32CZUS w/ Smoked Black Nickel Hardware

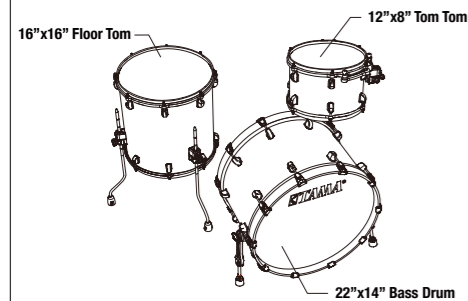

[22" BD 4pc Shell Kit]

MA42TZS w/ Chrome Hardware
MA42TZBNS w/ Black Nickel Hardware
MA42TZUS w/ Smoked Black Nickel Hardware

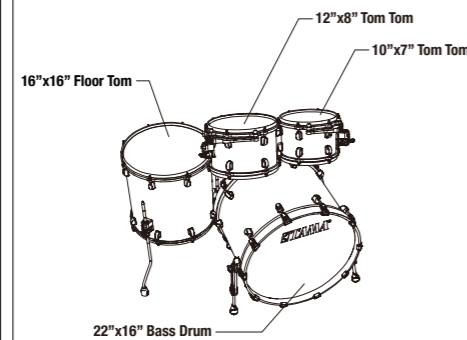

INDIVIDUAL MODEL NUMBERS

Diameter	Depth	Model No.		
		Black Nickel	Chrome	Smoked Black Nickel
Bass Drums *To order Bass Drum w/ Tom Holder Base, please substitute "Z" with "M". Ex: MAB2218Z → MAB2218M				
16"	12"	MAB1612ZBN	MAB1612Z	MAB1612ZU
18"	14"	MAB1814ZBN	MAB1814Z	MAB1814ZU
20"	14"	MAB2014ZBN	MAB2014Z	MAB2014ZU
20"	16"	MAB2016ZBN	MAB2016Z	MAB2016ZU
22"	14"	MAB2214ZBN	MAB2214Z	MAB2214ZU
22"	16"	MAB2216ZBN	MAB2216Z	MAB2216ZU
22"	18"	MAB2218ZBN	MAB2218Z	MAB2218ZU
24"	14"	MAB2414ZBN	MAB2414Z	MAB2414ZU
24"	16"	MAB2416ZBN	MAB2416Z	MAB2416ZU
Floor Toms				
13"	12"	MAF1312BN	MAF1312	MAF1312U
14"	12"	MAF1412BN	MAF1412	MAF1412U
14"	14"	MAF1414BN	MAF1414	MAF1414U
16"	14"	MAF1614BN	MAF1614	MAF1614U
16"	16"	MAF1616BN	MAF1616	MAF1616U
18"	16"	MAF1816BN	MAF1816	MAF1816U
Tom Toms				
8"	6"	MAT0806BN	MAT0806	MAT0806U
8"	7"	MAT0807BN	MAT0807	MAT0807U
10"	6.5"	MAT1065BN	MAT1065	MAT1065U
10"	7"	MAT1007BN	MAT1007	MAT1007U
10"	8"	MAT1008BN	MAT1008	MAT1008U
10"	9"	MAT1009BN	MAT1009	MAT1009U
12"	7"	MAT1207BN	MAT1207	MAT1207U
12"	8"	MAT1208BN	MAT1208	MAT1208U
12"	9"	MAT1209BN	MAT1209	MAT1209U
12"	10"	MAT1210BN	MAT1210	MAT1210U
13"	7.5"	MAT1375BN	MAT1375	MAT1375U
13"	9"	MAT1309BN	MAT1309	MAT1309U
13"	10"	MAT1310BN	MAT1310	MAT1310U
13"	11"	MAT1311BN	MAT1311	MAT1311U
14"	10"	MAT1410BN	MAT1410	MAT1410U
14"	11"	MAT1411BN	MAT1411	MAT1411U
14"	12"	MAT1412BN	MAT1412	MAT1412U
Snare Drums				
13"	6"	MAS136BN	MAS136	MAS136U
14"	5.5"	MAS1455BN	MAS1455	MAS1455U
14"	6.5"	MAS1465BN	MAS1465	MAS1465U
14"	8"	MAS148BN	MAS148	MAS148U

SPECIFICATIONS

Shells
All Maple Shell
TT/FT: 5mm, 6ply
BD/SD: 7mm, 8ply

Star-Cast Mounting System
Quick-Lock Tom Bracket
EVANS® Heads
Die-Cast Hoops
Hold Tight™ Washers
Claw Hooks w/ Rubber Spacers
Cushioned Floor Tom Legs

OPTION



MODEL NUMBER SYSTEM - Individual Drums

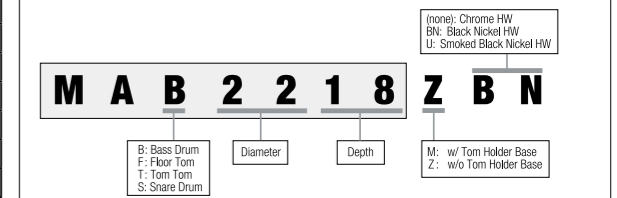

FINISHES (Lacquer)

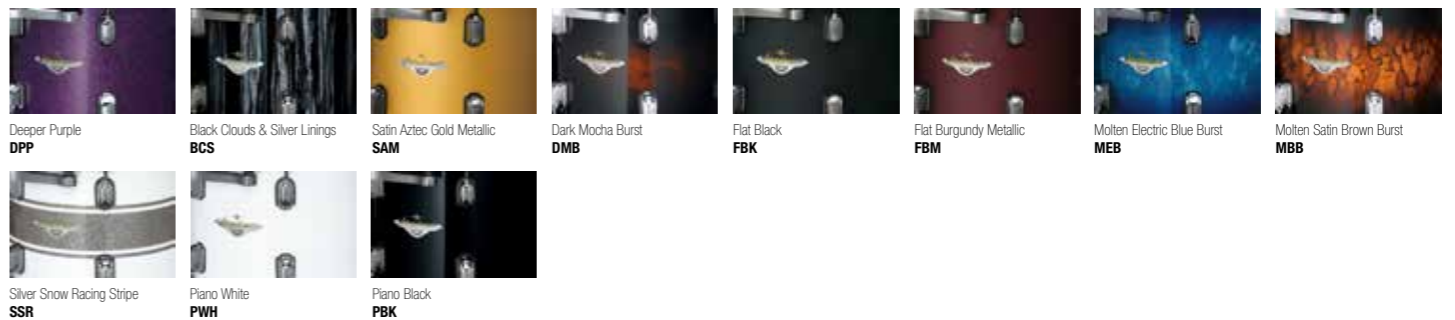

STARCLASSIC MAPLE

Duracover Wrap Finishes



COLOR Red Oyster **ROY**
w/ black nickel hardware

MR42TZBNS basic kit

including:
22"x16" bass drum
10"x7" tom tom
12"x8" tom tom
16"x16" floor tom

(add-on)
14"x6.5" snare drum

KIT CONFIGURATIONS LIST

[22" BD 3pc Shell Kit]

MR32CZS w/ Chrome Hardware
MR32CZBNS w/ Black Nickel Hardware
MR32CZUS w/ Smoked Black Nickel Hardware

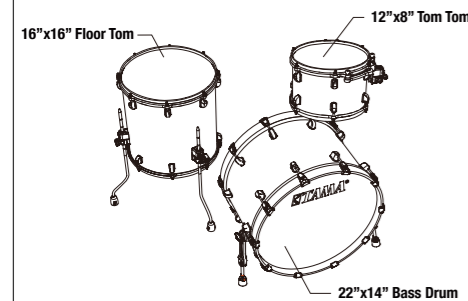

[22" BD 4pc Shell Kit]

MR42TZS w/ Chrome Hardware
MR42TZBNS w/ Black Nickel Hardware
MR42TZUS w/ Smoked Black Nickel Hardware

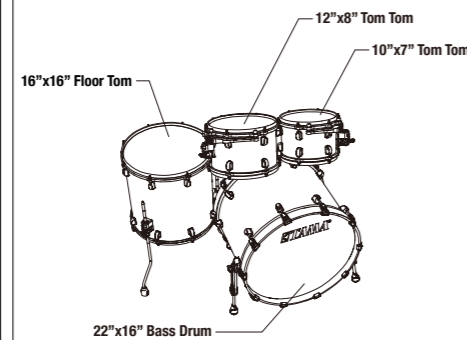

INDIVIDUAL MODEL NUMBERS

Diameter	Depth	Model No.		
		Black Nickel	Chrome	Smoked Black Nickel
Bass Drums *To order Bass Drum w/ Tom Holder Base, please substitute "Z" with "M". Ex MRB2218Z → MRB2218M				
16"	12"	MRB1612ZBN	MRB1612Z	MRB1612ZU
18"	14"	MRB1814ZBN	MRB1814Z	MRB1814ZU
20"	14"	MRB2014ZBN	MRB2014Z	MRB2014ZU
20"	16"	MRB2016ZBN	MRB2016Z	MRB2016ZU
22"	14"	MRB2214ZBN	MRB2214Z	MRB2214ZU
22"	16"	MRB2216ZBN	MRB2216Z	MRB2216ZU
22"	18"	MRB2218ZBN	MRB2218Z	MRB2218ZU
24"	14"	MRB2414ZBN	MRB2414Z	MRB2414ZU
24"	16"	MRB2416ZBN	MRB2416Z	MRB2416ZU
Floor Toms				
13"	12"	MRF1312BN	MRF1312	MRF1312U
14"	12"	MRF1412BN	MRF1412	MRF1412U
14"	14"	MRF1414BN	MRF1414	MRF1414U
16"	14"	MRF1614BN	MRF1614	MRF1614U
16"	16"	MRF1616BN	MRF1616	MRF1616U
18"	16"	MRF1816BN	MRF1816	MRF1816U
Tom Toms				
8"	6"	MRT0806BN	MRT0806	MRT0806U
8"	7"	MRT0807BN	MRT0807	MRT0807U
10"	6.5"	MRT1065BN	MRT1065	MRT1065U
10"	7"	MRT1007BN	MRT1007	MRT1007U
10"	8"	MRT1008BN	MRT1008	MRT1008U
10"	9"	MRT1009BN	MRT1009	MRT1009U
12"	7"	MRT1207BN	MRT1207	MRT1207U
12"	8"	MRT1208BN	MRT1208	MRT1208U
12"	9"	MRT1209BN	MRT1209	MRT1209U
12"	10"	MRT1210BN	MRT1210	MRT1210U
13"	7.5"	MRT1375BN	MRT1375	MRT1375U
13"	9"	MRT1309BN	MRT1309	MRT1309U
13"	10"	MRT1310BN	MRT1310	MRT1310U
13"	11"	MRT1311BN	MRT1311	MRT1311U
14"	10"	MRT1410BN	MRT1410	MRT1410U
14"	11"	MRT1411BN	MRT1411	MRT1411U
14"	12"	MRT1412BN	MRT1412	MRT1412U
Snare Drums				
13"	6"	MRS136BN	MRS136	MRS136U
14"	5.5"	MRS1455BN	MRS1455	MRS1455U
14"	6.5"	MRS1465BN	MRS1465	MRS1465U
14"	8"	MRS148BN	MRS148	MRS148U

SPECIFICATIONS

Shells
All Maple Shell
TT/FT: 5mm, 6ply
BD/SD: 7mm, 8ply

Star-Cast Mounting System
Quick-Lock Tom Bracket
EVANS® Heads
Die-Cast Hoops
Hold Tight™ Washers
Claw Hooks w/ Rubber Spacers
Cushioned Floor Tom Legs

OPTION



MODEL NUMBER SYSTEM - Individual Drums

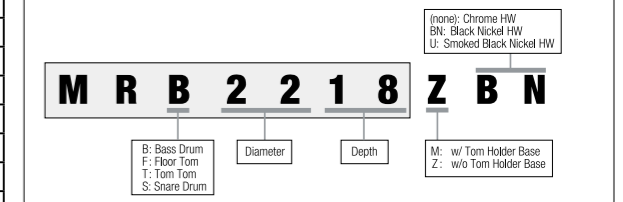

FINISHES (Duracover Wrap)

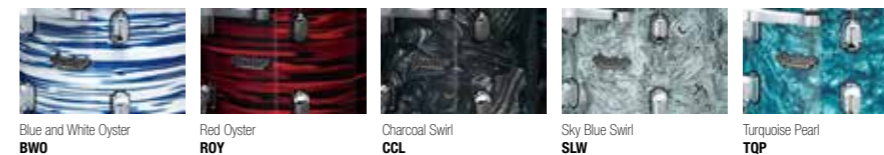

STARCLASSIC WALNUT/BIRCH

Lacquer Finishes

Exploring limitless possibilities, our result in the wake of countless experimentation came in the form of the Hybrid Shell Walnut/Birch: combining the superior quality warmth and mid to low frequency tone of the increasingly popular and truly unique Walnut, with the well-defined and uncompromisingly solid attack of Birch.

Whilst we successfully preserved their unique sonic trademarks, the characteristics of both Walnut and Birch blend to persuade a very focused sound that would define itself with great distinction within a musical ensemble; married with controlled sustain and clarity; all sealed with an undeniably palpable feeling of warmth and resonance when performed.



COLOR Molten Blue Ice Fade MBI

WBS52RZS basic kit

including:
 22"x16" bass drum
 10"x7" tom tom
 12"x8" tom tom
 14"x12" floor tom
 16"x14" floor tom
 MC69 single tom attachments (x2)
 [add-on]
 14"x6.5" snare drum

KIT CONFIGURATIONS LIST

[20" BD 3pc Shell Kit]

WBR30RS w/ Chrome Hardware

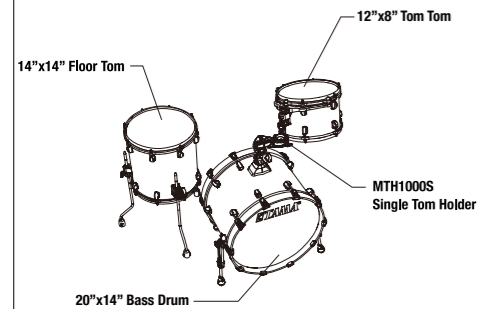

[22" BD 3pc Shell Kit]

WBS32RZS w/ Chrome Hardware

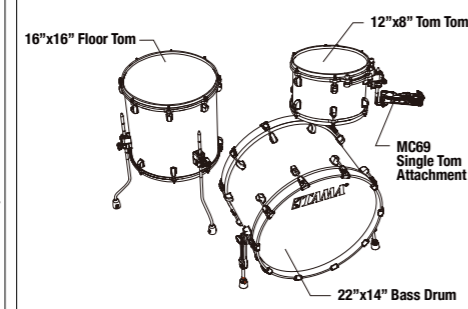

[22" BD 4pc Shell Kit]

WBS42S w/ Chrome Hardware

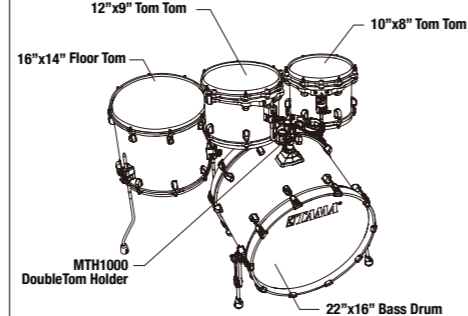

[22" BD 5pc Shell Kit]

WBS52RZS w/ Chrome Hardware

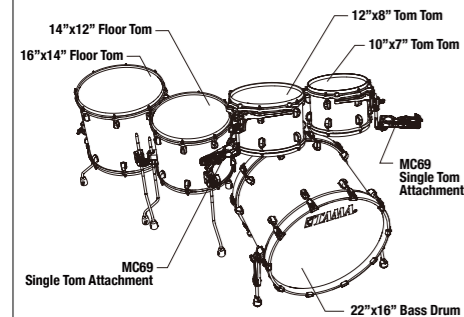

INDIVIDUAL MODEL NUMBERS

Diameter	Depth	Model No.
Bass Drums *To order Bass Drum w/ Tom Holder Base, please substitute "Z" with "M". Ex WBSB22DZ → WBSB22DM		
16"	12"	WBSB16HZ
18"	14"	WBSB18RZ
20"	14"	WBSB20RZ
20"	16"	WBSB20DZ
22"	14"	WBSB22RZ
22"	16"	WBSB22DZ
22"	18"	WBSB22EZ
24"	16"	WBSB24DZ
Floor Toms		
13"	12"	WBSF13R
14"	12"	WBSF14A
14"	14"	WBSF14D
16"	14"	WBSF16A
16"	16"	WBSF16D
18"	16"	WBSF18D
Tom Toms		
8"	6"	WBST8H
8"	7"	WBST8A
10"	6.5"	WBST10H
10"	7"	WBST10R
10"	8"	WBST10A
12"	7"	WBST12H
12"	8"	WBST12R
12"	9"	WBST12A
13"	7.5"	WBST13H
13"	9"	WBST13R
13"	10"	WBST13A
14"	11"	WBST14A
14"	12"	WBST14D
Snare Drums		
13"	6"	WBSS136
14"	5.5"	WBSS55
14"	6.5"	WBSS65
14"	8"	WBSS148

MODEL NUMBER SYSTEM - Individual Drums

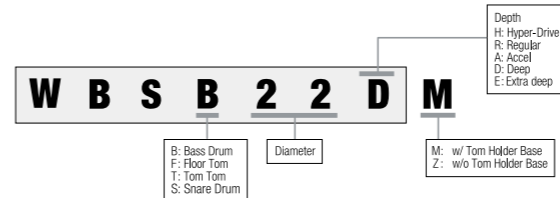

SPECIFICATIONS

Shells
 TT/FT/SD: 6mm, 4ply European Birch + 2 inner ply American Black Walnut
 BD: 8mm, 5ply European Birch + 2 inner ply American Black Walnut

Star-Cast Mounting System Claw Hooks w/ Rubber Spacers
Quick-Lock Tom Bracket Cushioned Floor Tom Legs
EVANS® Heads Die-Cast Hoops

FINISHES (Lacquer)



STARCLASSIC WALNUT/BIRCH

Duracover Wrap Finishes



COLOR Turquoise Pearl **TOP**

WBR32RZS basic kit

including:
22"x14" bass drum
12"x8" tom tom
16"x16" floor tom
MC69 single tom attachment

[add-on]
14"x6.5" snare drum

KIT CONFIGURATIONS LIST

[20" BD 3pc Shell Kit]

WBR30RS w/ Chrome Hardware

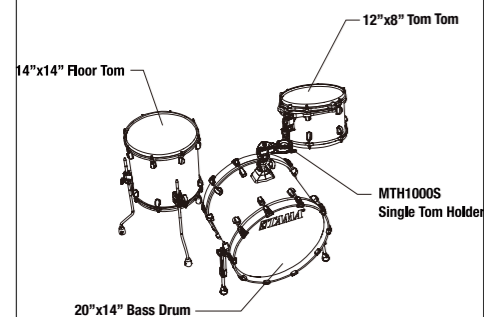

[22" BD 3pc Shell Kit]

WBR32RZS w/ Chrome Hardware

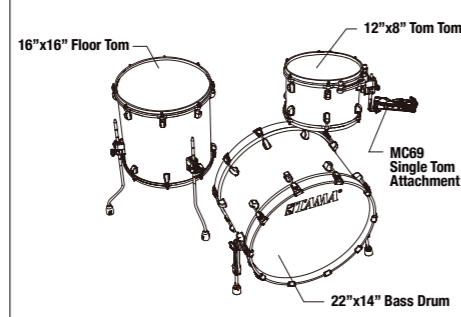

[22" BD 4pc Shell Kit]

WBR42S w/ Chrome Hardware

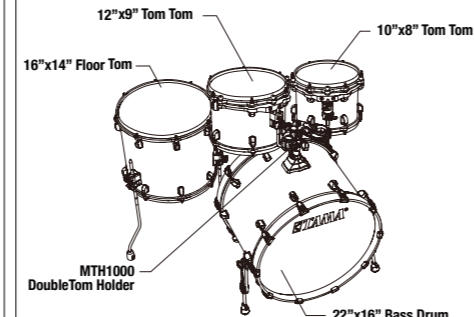

[22" BD 5pc Shell Kit]

WBR52RZS w/ Chrome Hardware

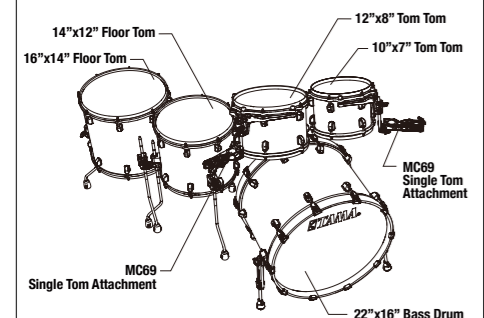

INDIVIDUAL MODEL NUMBERS

Diameter	Depth	Model No.
Bass Drums *To order Bass Drum w/ Tom Holder Base, please substitute "Z" with "M". Ex WBRB22DZ -> WBRB22DM		
16"	12"	WBRB16HZ
18"	14"	WBRB18RZ
20"	14"	WBRB20RZ
20"	16"	WBRB20DZ
22"	14"	WBRB22RZ
22"	16"	WBRB22DZ
22"	18"	WBRB22EZ
24"	16"	WBRB24DZ
Floor Toms		
13"	12"	WBRF13R
14"	12"	WBRF14A
14"	14"	WBRF14D
16"	14"	WBRF16A
16"	16"	WBRF16D
18"	16"	WBRF18D
Tom Toms		
8"	6"	WBRT8H
8"	7"	WBRT8A
10"	6.5"	WBRT10H
10"	7"	WBRT10R
10"	8"	WBRT10A
12"	7"	WBRT12H
12"	8"	WBRT12R
12"	9"	WBRT12A
13"	7.5"	WBRT13H
13"	9"	WBRT13R
13"	10"	WBRT13A
14"	11"	WBRT14A
14"	12"	WBRT14D
Snare Drums		
13"	6"	WBRS136
14"	5.5"	WBRS55
14"	6.5"	WBRS65
14"	8"	WBRS148

MODEL NUMBER SYSTEM - Individual Drums

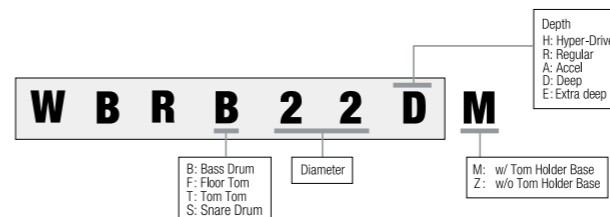

SPECIFICATIONS

Shells

TT/FT/SD: 6mm, 4ply European Birch + 2 inner ply American Black Walnut
BD: 8mm, 5ply European Birch + 2 inner ply American Black Walnut

Star-Cast Mounting System

Quick-Lock Tom Bracket

EVANS® Heads

Claw Hooks w/ Rubber Spacers

Cushioned Floor Tom Legs

Die-Cast Hoops

FINISHES (Duracover Wrap)

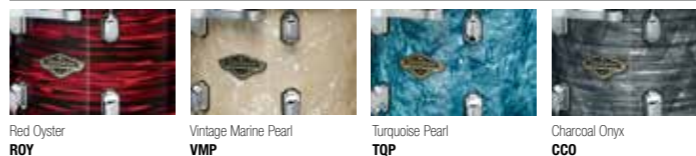

STARCLASSIC PERFORMER

Lacquer Finishes

Tama's newest Starclassic Performer series centers on the newest Tama hybrid shell – maple/birch – to offer drummers a complex, powerful and expressive sound supported by rugged Starclassic performance. Tama's Starclassic Performer series evolves the Starclassic legacy to provide a unique Tama sonic component that redefines the art of professional drum set sound and expression at an undeniable value.



COLOR Sky Blue Aurora SKA

MBS52RZS basic kit

including:
 22"x16" bass drum
 10"x7" tom tom
 12"x8" tom tom
 14"x12" floor tom
 16"x14" floor tom
 MC69 single tom attachments (x2)

[add-on]
 14"x6.5" snare drum

KIT CONFIGURATIONS LIST

[22" BD 4pc Shell Kit]

MBS42S w/ Chrome Hardware

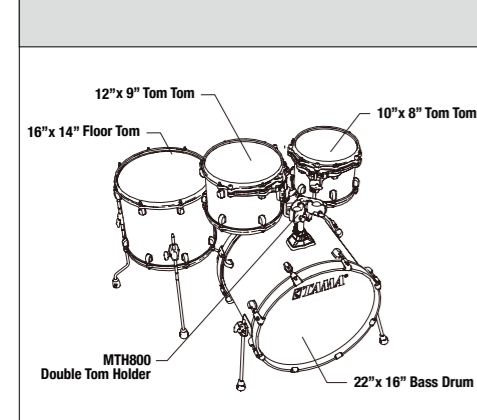

[22" BD 5pc Shell Kit]

MBS52RZS w/ Chrome Hardware

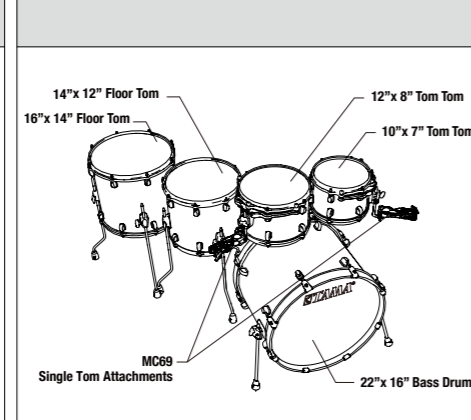

INDIVIDUAL MODEL NUMBERS

Diameter	Depth	Model No.		
Bass Drums *To order Bass Drum w/ Tom Holder Base, please substitute "Z" with "M". Ex MBSB22DZ → MBSB22DM				
18"	14"	MBSB18RZ		
20"	14"	MBSB20RZ		
22"	16"	MBSB22DZ		
22"	18"	MBSB22EZ		
24"	16"	MBSB24DZ		
Floor Toms				
14"	12"	MBSF14A		
14"	14"	MBSF14D		
16"	14"	MBSF16A		
18"	16"	MBSF18D		
Tom Toms				
8"	6"	MBST8H		
8"	7"	MBST8A		
10"	7"	MBST10R		
10"	8"	MBST10A		
12"	8"	MBST12R		
12"	9"	MBST12A		
13"	9"	MBST13R		
13"	10"	MBST13A		
Snare Drums				
14"	5.5"	MBSS55		
14"	6.5"	MBSS65		

MODEL NUMBER SYSTEM - Individual Drums

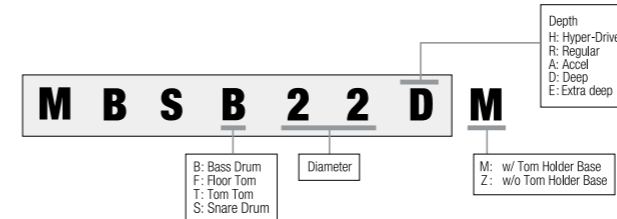

SPECIFICATIONS

Shells

TT/FT/SD: 6mm, 4ply Birch + 2 inner ply Maple
 BD: 7mm, 5ply Birch + 2 inner ply Maple

Star-Cast Mounting System Claw Hooks w/ Rubber Spacers
 Cushioned Floor Tom Legs EVANS® Heads
 Die-Cast Hoops

FINISHES (Lacquer)

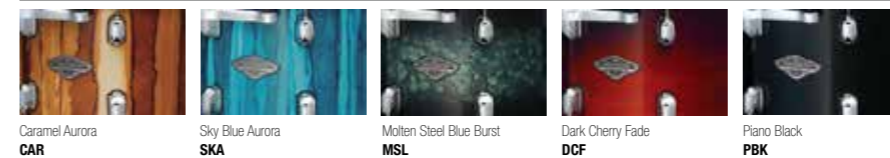

SUPERSTAR CLASSIC

Exotic Finishes

For more than forty years, the Superstar name has stood for groundbreaking design, superior build quality, sterling tone, and clear projection. Superstar Classic once again upholds tradition by raising the bar for discerning drummers—and remarkably—does it while also lowering the price. Drawing on Superstar of the past, its classic TAMA T-shape badge and streamlined low-mass single lugs point to the simpler state of art of the 70's, while the ingenious Star-Mount system and the thinner gauge 100% maple shells eclipse anything in its class.



COLOR Caribbean Lacebark Pine Fade **PCLP**

CL72RS 7pc basic kit

including:
 22"x16" bass drum
 8"x6" tom tom
 10"x7" tom tom
 12"x8" tom tom
 14"x12" floor tom
 16"x14" floor tom
 14"x6.5" snare drum
 MTH600 double tom holder
 MC69 single tom attachment

KIT CONFIGURATIONS LIST

[22" BD 5pc Shell Kit]

CL52KRS
CL52KR w/SM5W hardware pack

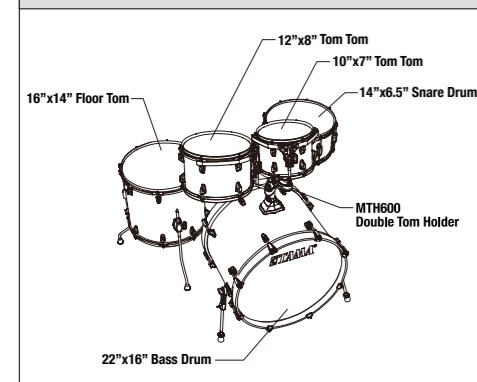

[22" BD 7pc Shell Kit]

CL72RS
CL72R w/SM5W hardware pack

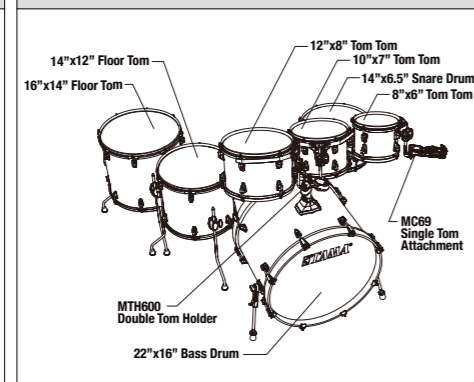

INDIVIDUAL MODEL NUMBERS

Diameter	Depth	Model No.		
Bass Drums				
18" (w/ bass drum lifter)	14"	CLB18RL		
20"	16"	CLB20D		
22"	16"	CLB22D		
24"	16"	CLB24D		
Floor Toms				
14"	12"	CLF14A		
14"	14"	CLF14D		
16"	14"	CLF16A		
18"	16"	CLF18D		
Tom Toms				
8"	6"	CLT8H		
10"	7"	CLT10R		
12"	8"	CLT12R		
13"	9"	CLT13R		
Snare Drums				
14"	5"	CLS145		
14"	6.5"	CLS1465		

SPECIFICATIONS

Shells

TT/FT/SD: 5mm 4ply Maple + 2 outer ply Lacebark Pine
 BD: 7mm 6ply Maple + 2 outer ply Lacebark Pine

Star-Mount System

Low-Mass Lugs

Power Craft II Drum Heads

FINISHES (Lacquer)



Caribbean Lacebark Pine Fade
PCLP



Gloss Garnet Lacebark Pine
PGGP



Gloss Sapphire Lacebark Pine
PGHP



Gloss Java Lacebark Pine
PGJP



Gloss Lacebark Pine Fade
PGLP

SUPERSTAR CLASSIC

Lacquer Finishes



COLOR Gloss Natural Blonde **GNL**

CL52KRS 5pc basic kit

including:
 22"x16" bass drum
 10"x7" tom tom
 12"x8" tom tom
 16"x14" floor tom
 14"x6.5" snare drum
 MTH600 double tom holder

KIT CONFIGURATIONS LIST

[22" BD 3pc Shell Kit]

CL32RZS
CL32RZ w/SM5W hardware pack

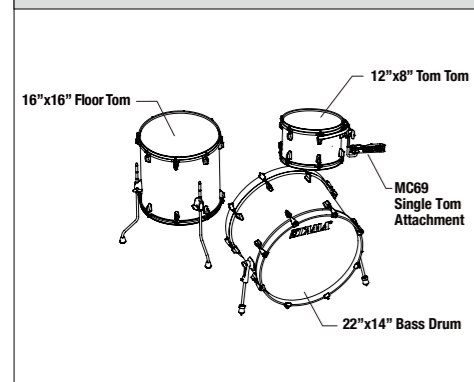

[20" BD 5pc Shell Kit]

CL50RS
CL50R w/SM5W hardware pack

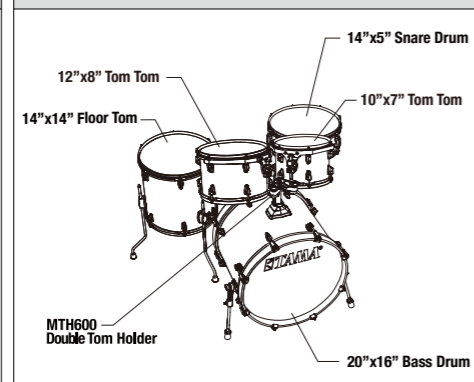

[22" BD 5pc Shell Kit]

CL52KRS
CL52KR w/SM5W hardware pack

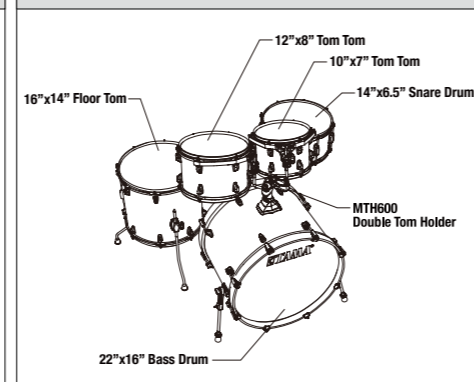

INDIVIDUAL MODEL NUMBERS

Diameter	Depth	Model No.		
Bass Drums				
18" (w/ bass drum lifter)	14"	CLB18RL		
20"	16"	CLB20D		
22"	14"	CLB22RZ		
22"	16"	CLB22D		
24"	16"	CLB24D		
Floor Toms				
14"	12"	CLF14A		
14"	14"	CLF14D		
16"	14"	CLF16A		
16"	16"	CLF16D		
18"	16"	CLF18D		
Tom Toms				
8"	6"	CLT8H		
10"	7"	CLT10R		
12"	8"	CLT12R		
13"	9"	CLT13R		
Snare Drums				
14"	5"	CLS145		
14"	6.5"	CLS1465		

SPECIFICATIONS

Shells

All Maple Shell
 TT/FT/SD: 5mm 6ply
 BD: 7mm 8ply

Star-Mount System

Low-Mass Lugs

Power Craft II Drum Heads

FINISHES (Lacquer)



Gloss Natural Blonde
GNL



Blue Lacquer Burst
BAB



Coffee Fade
CFF



Tangerine Lacquer Burst
TLB



Transparent Black Burst
TPB

SUPERSTAR CLASSIC

Unicolor Wrap Finishes



COLOR Ice Ash Wrap ICA

CK52KRS 5pc basic kit

including:
 22"x16" bass drum
 10"x7" tom tom
 12"x8" tom tom
 16"x14" floor tom
 14"x6.5" snare drum
 MTH600 double tom holder

KIT CONFIGURATIONS LIST

[22" BD 3pc Shell Kit]

CK32RZS
 CK32RZ w/SM5W hardware pack

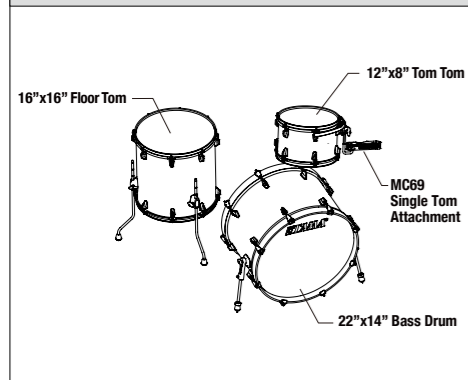

[20" BD 5pc Shell Kit]

CK50RS
 CK50R w/SM5W hardware pack

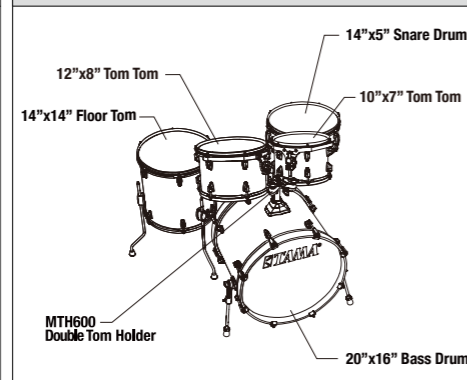

[22" BD 5pc Shell Kit]

CK52KRS
 CK52KR w/SM5W hardware pack

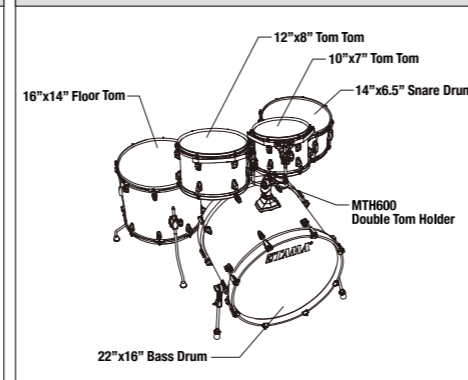

INDIVIDUAL MODEL NUMBERS

Diameter	Depth	Model No.		
Bass Drums				
18" (w/ bass drum lifter)	14"	CKB18RL		
20"	16"	CKB20D		
22"	14"	CKB22RZ		
22"	16"	CKB22D		
24"	16"	CKB24D		
Floor Toms				
14"	12"	CKF14A		
14"	14"	CKF14D		
16"	14"	CKF16A		
16"	16"	CKF16D		
18"	16"	CKF18D		
Tom Toms				
8"	6"	CKT8H		
10"	7"	CKT10R		
12"	8"	CKT12R		
13"	9"	CKT13R		
Snare Drums				
14"	5"	CKS145		
14"	6.5"	CKS1465		

SPECIFICATIONS

Shells

All Maple Shell
 TT/FT/SD: 5mm 6ply
 BD: 7mm 8ply

Star-Mount System

Low-Mass Lugs

Power Craft II Drum Heads

FINISHES (Unicolor Wrap)



Ice Ash Wrap
ICA



Natural Ebony Tiger Wrap
NET



Indigo Sparkle
ISP



Midnight Gold Sparkle
MGD

IMPERIALSTAR

Unicolor Wrap Finishes w/Chrome Shell Hardware

In 2006, the Imperialstar line made its successful comeback, providing everything a drummer needs at an affordable price. Now, Imperialstar is refined to feature matching bass drum hoops, Stage Master double-braced hardware, and Iron Cobra 200 bass drum pedal.



COLOR Electric Yellow ELY

IP52H6W 22" Bass Drum 5pc basic kit

Drums: 22"x18" bass drum, 10"x7" & 12"x8" tom toms, 16"x14" floor tom, 14"x5" snare drum.

Hardware: double tom holder, hi-hat stand, drum pedal, snare stand, boom cymbal stand, straight cymbal stand, drum throne.

KIT CONFIGURATIONS LIST

[18" BD 5pc Kit w/ Hardware]

IP58H6W

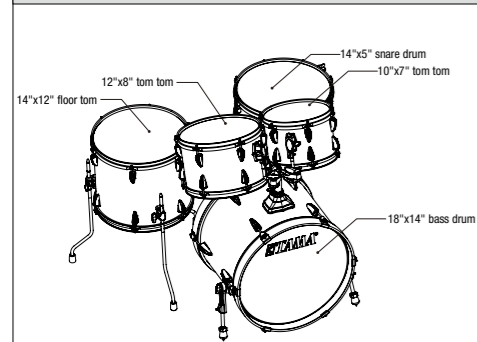

[20" BD 5pc Kit w/ Hardware]

IP50H6W

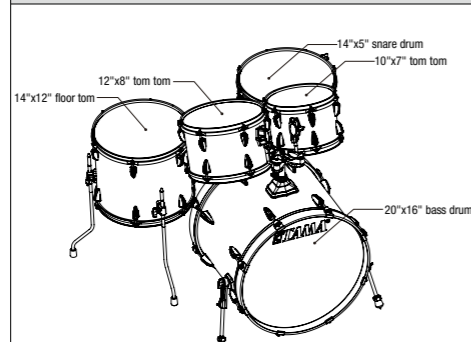

[22" BD 5pc Kit w/ Hardware]

IP52H6W

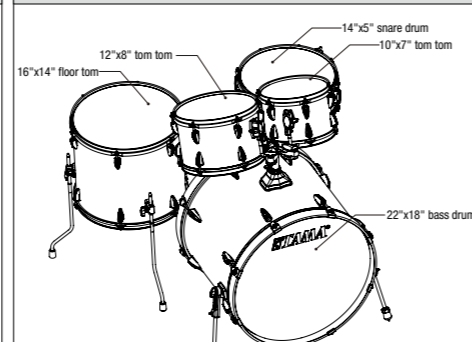

[22" BD 6pc Kit w/ Hardware]

IP62H6W

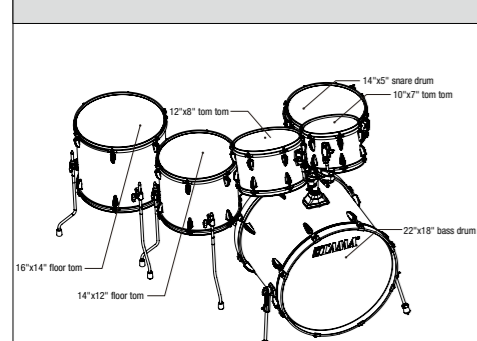

INDIVIDUAL MODEL NUMBERS

Diameter	Depth	Model No.		
Bass Drums				
18"	14"	IPB18RW		
20"	16"	IPB20DW		
22"	18"	IPB22EW		
Floor Toms				
14"	12"	IPF14A		
16"	14"	IPF16A		
18"	16"	IPF18D		
Tom Toms				
8"	7"	IPT8A		
10"	7"	IPT10R		
12"	8"	IPT12R		
13"	9"	IPT13R		
Snare Drums				
14"	5"	IPS145		
14"	6.5"	IPS1465		

SPECIFICATIONS

Shells

All Poplar Shell: 8mm 6ply

Omnisphere Tom Holder
Wood Bass Drum Hoops
Double Braced Hardware

FINISHES (Unicolor Wrap)



Coffee Teak Wrap
CTW



Burnt Red Mist
BRM



Electric Yellow
ELY



Hairline Black
HBK



Hairline Blue
HLB

IMPERIALSTAR

Unicolor Wrap Finish w/Black Nickel Shell Hardware



COLOR Blacked Out Black **BOB**

IP52H6WBN 22" Bass Drum 5pc basic kit

Drums: 22"x18" bass drum, 10"x7" & 12"x8" tom toms, 16"x14" floor tom, 14"x5" snare drum.

Hardware: double tom holder, hi-hat stand, drum pedal, snare stand, boom cymbal stand, straight cymbal stand, drum throne.

KIT CONFIGURATIONS LIST

[20" BD 5pc Kit w/ Hardware]

IP50H6WBN

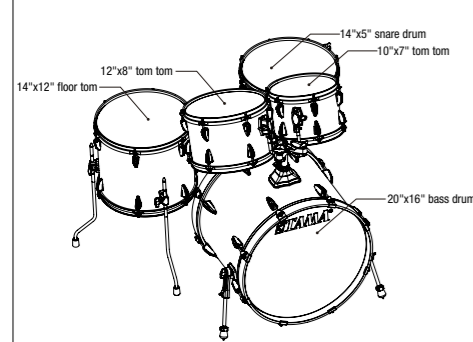

[22" BD 5pc Kit w/ Hardware]

IP52H6WBN

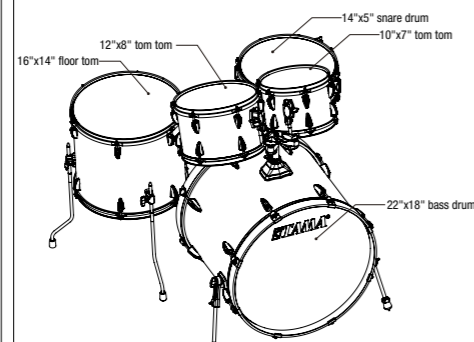

INDIVIDUAL MODEL NUMBERS

Diameter	Depth	Model No.		
Bass Drums				
18"	14"	IPB18RWB		
20"	16"	IPB20DWB		
22"	18"	IPB22EWB		
Floor Toms				
14"	12"	IPF14AB		
16"	14"	IPF16AB		
18"	16"	IPF18DB		
Tom Toms				
8"	7"	IPT8AB		
10"	7"	IPT10RB		
12"	8"	IPT12RB		
13"	9"	IPT13RB		
Snare Drums				
14"	5"	IPS145B		
14"	6.5"	IPS1465B		

SPECIFICATIONS

Shells

All Poplar Shell: 8mm 6ply

Omnisphere Tom Holder
Wood Bass Drum Hoops
Double Braced Hardware

FINISH (Unicolor Wrap)



Blacked Out Black
BOB

STAGESTAR

Unicolor Wrap Finishes

With 50 years of experience, TAMA knows what drummers really want. Which is why TAMA has the set you need, want and can afford no matter how long you've been playing drums or what budget you have to work with. Now TAMA has launched the affordable kit to ever incorporate many nice features – STAGESTAR. The new STAGESTAR kit comes with Omni-ball tom holder as well as double braced hardware for increased stability.



COLOR Candy Red Sparkle **CDS**

ST52H5 22" Bass Drum 5pc basic kit

Drums:
22" x 16" bass Drum, 10" x 8" tom tom, 12" x 9" tom tom, 16" x 15" floor tom, 14" x 5.5" snare drum.

Hardware:
double tom holder, hi-hat stand, drum pedal, snare stand, boom cymbal stand, drum throne.

[Add-on Cymbals]

To order the kit with cymbals, please add "C" to the model number.
ex) ST52H6 --- ST52H6C

CLUB-JAM

Lacquer Finishes

The "Club-JAM" Kit adopts some ideas from vintage kits, such as a cymbal holder mounted directly on the bass drum shell and curved bass drum spurs, further setting it apart from the typical compact kit. Focused yet deep sound from Poplar shell is just right for small and intimate gigs. Its compact size and configuration make it ideal for working drummers, and it fits comfortably on just about any stage.



COLOR Satin Burgundy Elm **SBE**

LJL48S 18" Bass Drum 4pc basic kit

Drums:
18"x12" bass drum, 10"x7" tom tom, 14"x7" floor tom, 13"x5" snare drum.

Hardware:
single tom holder, cymbal holder.

LJL48H4 18" Bass Drum 4pc basic kit w/ hardware

Drums:
18"x12" bass drum, 10"x7" tom tom, 14"x7" floor tom, 13"x5" snare drum.

Hardware:
single tom holder, hi-hat stand, drum pedal, snare stand, cymbal holder, drum throne.

KIT CONFIGURATIONS LIST

[20" BD 5pc Kit w/ Hardware]

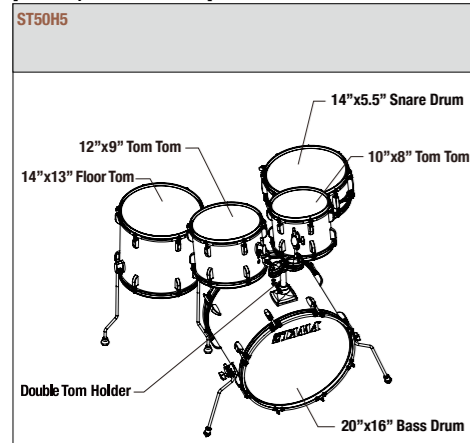

[22" BD 5pc Kit w/ Hardware]

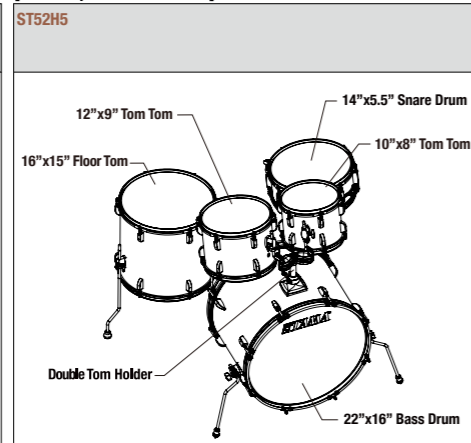

KIT CONFIGURATION LIST

[18" BD 4pc Shell Kit]

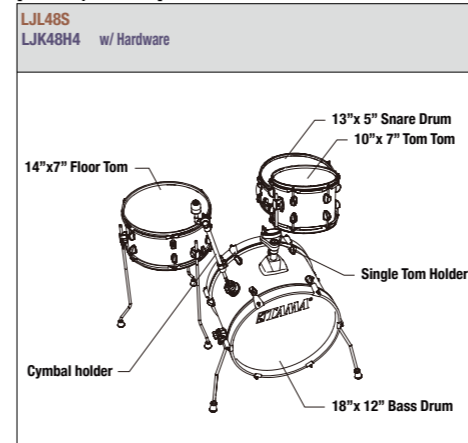

FINISHES (Unicolor Wrap)



FINISHES (Lacquer)



CLUB-JAM

Unicolor Wrap Finishes



COLOR Candy Apple Mist **CPM**

LJK48S 18" Bass Drum 4pc basic kit

Drums:
18"x12" bass drum, 10"x7" tom tom, 14"x7" floor tom, 13"x5" snare drum.

Hardware:
Single tom holder, cymbal holder.

LJK48H4 18" Bass Drum 4pc basic kit w/ hardware

Drums:
18"x12" bass drum, 10"x7" tom tom, 14"x7" floor tom, 13"x5" snare drum.

Hardware:
Single tom holder, hi-hat stand, drum pedal, snare stand, cymbal holder, drum throne.

CLUB-JAM MINI

Unicolor Wrap Finishes

The simple and sweet TAMA Club-JAM Mini kit is just a kick and snare. Its clear yet deep sound from the Poplar shell is just right for those small and intimate gigs. While its compact size and configuration fit comfortably at any small venue or street show. The Drum Bag Set for this kit (DSS28LJ) allows for smooth transportation (sold separately). If one needs to configure it as a regular drum kit, also available are add-on drums including the 10"x7" tom tom with attachment and a 14"x7" floor tom.



COLOR Indigo Sparkle **ISP**

LJK28S 18" Bass Drum 2pc basic kit

Drums:
18"x7" bass drum, 12"x5" snare drum.

LJK28H4 18" Bass Drum 2pc basic kit w/ hardware

Drums:
18"x7" bass drum, 12"x5" snare drum.

Hardware:
hi-hat stand, drum pedal, snare stand, drum throne.

LJKT10F14 Add-on pack

Add-on tom and floor tom package is sold separately.
10"x7" tom tom, 14"x7" floor tom, single tom attachment

KIT CONFIGURATION LIST

[18" BD 4pc Shell Kit]

LJK48S
LJK48H4 w/ Hardware

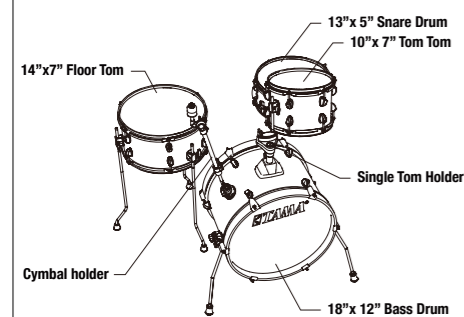

KIT CONFIGURATION LIST

[18" BD 2pc Shell Kit]

LJK28S
LJK28H4 w/ Hardware

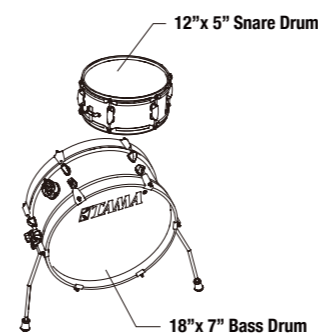

FINISHES (Unicolor Wrap)

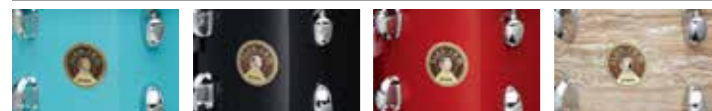

Aqua Blue
AOB

Charcoal Mist
CCM

Candy Apple Mist
CPM

Cream Marble Wrap
CMW

FINISHES (Unicolor Wrap)



Aqua Blue
AOB

Charcoal Mist
CCM

Candy Apple Mist
CPM

Indigo Sparkle
ISP

NEW

CLUB-JAM FLYER

Unicolor Wrap Finishes

The Club-JAM Flyer is the ultimate compact-sized drum kit. It features a 14"x10" bass drum with bass drum lifter, 8"x6" tom tom, 10"x9" floor tom and a 10"x5" snare drum. The Club-JAM Flyer kit delivers a very-well balanced authentic drum sound despite its smaller-sized shells. The Club-JAM Flyer kit's compact size and configuration make it perfect for any small venue or street show. A special drum bag set for the Club-JAM Flyer kit allows for easy transportation (DSS44LJ / sold separately).



COLOR Indigo Sparkle **ISP**

LJK44S 14" Bass Drum 4pc basic kit

Drums:
14"x10" bass drum w/ bass drum lifter, 8"x6" tom tom, 10"x9" floor tom, 10"x5" snare drum.

Hardware:
Single tom holder.

LJK44H4 14" Bass Drum 4pc basic kit w/ hardware

Drums:
14"x10" bass drum w/ bass drum lifter, 8"x6" tom tom, 10"x9" floor tom, 10"x5" snare drum.

Hardware:
Single tom holder, hi-hat stand, drum pedal, snare stand, drum throne.

CLUB-JAM PANCAKE

Unicolor Wrap Finishes

The Club-JAM Pancake kit combines the benefits of a compact & easily portable drum kit with professional quality sound and durability. This is achieved through the lightweight and minimalist design of the Club-JAM series. As the lightest and smallest option in the Club-JAM series, this Club-JAM Pancake kit offers a professional quality sound in any situation. The 3.5" deep tom and floor tom, paired with a 4" deep snare drum and bass drum can be easily packed in just a single bag thanks to the ultrashallow shell. The single-headed toms produce a crisp and warm sound with a strong attack. The double-headed snare drum produces a bright and sharp sound, along with significant low-end from the double-headed bass drum. For every genre, whether you're playing live or in the studio, the Club-JAM Pancake kit delivers a new, unique, and satisfying musical experience.



COLOR Burnt Red Mist **BRM**

LJK48P 18" Bass Drum 4pc basic kit

Drums:
18"x4" bass drum, 10"x3.5" tom tom, 13"x3.5" floor tom, 12"x4" snare drum.

Hardware:
Single tom attachment

LJKB18H3 Bass Drum

Drums:
18"x4" bass drum

KIT CONFIGURATION LIST

[14" BD 4pc Shell Kit]

LJK44S
LJK44H4 w/ Hardware

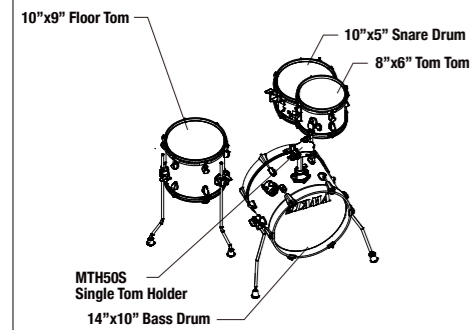

KIT CONFIGURATION LIST

[18" BD 4pc Shell Kit]

LJK48P

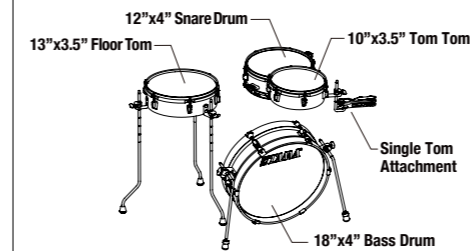

FINISHES (Unicolor Wrap)



Aqua Blue
AQB

Candy Apple Mist
CPM

Indigo Sparkle
ISP

NEW

FINISHES (Unicolor Wrap)



Heiline Black
HBK

Burnt Red Mist
BRM

COCKTAIL-JAM

Unicolor Wrap Finishes

The Cocktail-JAM Kit™ is a TAMA original in both appearance and sound. It's ideal for hip-hop, jazz, intimate acoustic settings, and tight rehearsal rooms. Completely compact, this kit can easily be set up and played using a throne in spaces much smaller than a typical drum set. Additionally, the Cocktail-JAM Kit and its hardware can be easily packed into just two bags (included with the kit), making it super portable and easy to transport to any gig. Have fun jamming with the Cocktail-JAM Kit!



COLOR Bright Orange Sparkle **BOS**

CJB46 basic kit

Drums:
16"x6" bass drum, 10"x5" tom tom, 14"x5.5" floor tom, 12"x5" snare drum, Sound Focus Pad, drum bag, hardware bag.

Hardware:
Single tom attachments (x2), single pedal.

CJB46C basic kit w/ cymbal attachments

Drums:
16"x6" bass drum, 10"x5" tom tom, 14"x5.5" floor tom, 12"x5" snare drum, Sound Focus Pad, drum bag, hardware bag.

Hardware:
Single tom attachments (x2), single pedal, cymbal attachment, hi-hat attachment.

KIT CONFIGURATION LIST

[16" BD 4pc Kit]

CJB46
CJB46C w/ MCAX5366 Clamp Kit

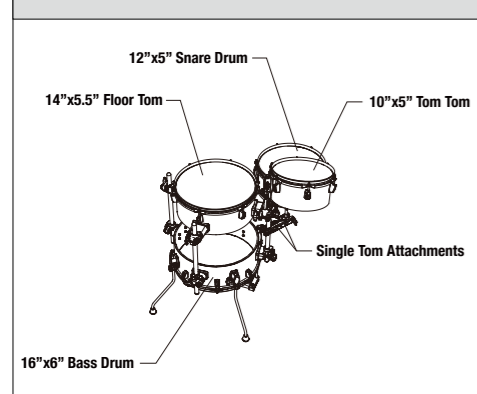

FINISHES (Unicolor Wrap)



Bright Orange Sparkle
BOS



Indigo Sparkle
ISP



Midnight Gold Sparkle
MGD

TRUE TOUCH TRAINING KIT

True Touch Training Kit is a revolutionary practice kit that not only offers the low volume required for practicing at home, but also allows drummers to perform critical technique refinement needed to improve their musical expression. The combination of quiet acoustic volume, realistic acoustic touch and sensitive dynamic expression results in a highly satisfying acoustic drum feeling, something that has not been possible with conventional practice kits until now.



TTK5S Complete Kit

including:
Solid Kick Bass Pad
AAD Snare Pad
8" high tom pad w/ mounting clamp
8.5" low tom pad w/ mounting clamp
9" floor tom w/ clamp & boom arm & L-rod
Tom stand

*Hi-hat stand, cymbal stand, kick pedal, snare stand and cymbals are not included.

KIT CONFIGURATIONS LIST

[TTK5S 5pc Kit]



*Hi-hat stand, cymbal stand, kick pedal and cymbals are not included.

including:
Solid Kick Bass Pad
AAD Snare Pad
8" high tom pad w/ mounting clamp
8.5" low tom pad w/ mounting clamp
9" floor tom w/ clamp & boom arm & L-rod
Tom stand

[TTK4S 4pc Kit]



*Hi-hat stand, cymbal stand, kick pedal and cymbals are not included.

including:
Solid Kick Bass Pad
AAD Snare Pad
8" high tom pad w/ mounting clamp
9" floor tom w/ clamp & boom arm & L-rod
Tom stand

[TTK2S 2pc Kit]



*Hi-hat stand, cymbal stand, kick pedal and cymbals are not included.

including:
Solid Kick Bass Pad
AAD Snare Pad

ADD-ON ITEMS

AAD Snare Pad



TTSD10

Acousti-Tone Tom Pad



TTHT8 8" tom tom
TTLT8.5 8.5" tom tom
*Mounting clamp is included.

Acousti-Tone Floor Tom Pad



TTFT9 9" floor tom
*Mounting Clamp, boom arm & L-Rod are included.

Solid Kick Bass Pad



TTBD6

Tom Stand



TTKTS

SNARE DRUMS

TAMA has a wide variety of snare drum options to complement our array of drum kits. From our super high end STAR snare drums to the METALWORKS series, which offers quality at a great price, there is a model to fit every drummer's desired sound and budget.

STAR BUBINGA



Color: Natural Indian Laurel -LNTI

TBS1465S

Please refer to the STAR Bubinga drum kit page to see available sizes, finishes, and inlay options.

Lug: MSL90SC
Hoop: Die-Cast Hoop (8 hole)
Strainer/Butt: MLS50A / MLS50B
Snare Wire: 14"=MS20RL14C, 13"=MS20RL13C

STAR MAPLE



Color: Gloss Natural Curly Maple -RGCM

TMS1465S

Please refer to the STAR Maple drum kit page to see available sizes, finishes, and inlay options.

Lug: MSL90SC
Hoop: Die-Cast Hoop (8 hole)
Strainer/Butt: MLS50A / MLS50B
Snare Wire: 14"=MS20RL14C, 13"=MS20RL13C

STAR WALNUT



Color: Garnet Japanese Sen Burst - AGJB

TWS1465

Please refer to the STAR Walnut drum kit page to see available sizes and finishes.

Lug: MSL90SC
Hoop: Die-Cast Hoop (8 hole)
Strainer/Butt: MLS50A / MLS50B
Snare Wire: 14"=MS20RL14C, 13"=MS20RL13C

STAR SOLID MAHOGANY



Color: Oiled Natural Mahogany -OMH

TLH146S

Shell: 7mm Solid Mahogany w/ 7mm Sound Focus Rings
Size: 14"x6"
Lug: MSL90SC
Hoop: Die-Cast Hoop (8 hole)
Strainer/Butt: MLS50A / MLS50B
Snare Wire: MS20RL14C
Color: Oiled Natural Mahogany (OMH)
[Inlay Option] Outside Inlay, or w/o Inlay

STAR STAVE WALNUT



Color: Oiled Natural Walnut -OWN

TVW146S

Shell: 10mm, 16pcs Stave Walnut
Size: 14"x6"
Lug: MSL90SC
Hoop: Die-Cast Hoop (8 hole)
Strainer/Butt: MLS50A / MLS50B
Snare Wire: MS20RL14C
Color: Oiled Natural Walnut (OWN)
[Inlay Option] Outside Inlay, or w/o Inlay

STAR RESERVE SOLID MAPLE



Color: Oiled Natural Maple -OMP

TLM145S

Shell: 8mm Solid Maple w/ 8mm Solid Maple Sound Focus Rings
Size: 14"x5"
Lug: MTL150
Hoop: 2.3mm Brass Sound Arc Hoop (8 hole)
Strainer/Butt: MLS50A / MLS50B
Snare Wire: MS20RL14C
Color: Oiled Natural Maple (OMP)

STAR RESERVE BUBINGA/MAPLE



Color: Caramel Olive Ash Burst -OCOB

TMBS158S

Shell: 5.5mm, 8ply Bubinga/Maple (1inner ply Cordia+2ply Bubinga+4ply Maple+1outer ply Olive Ash)
Size: 15"x8"
Lug: MSL90TC
Hoop: Brass Mighty Hoop (8 hole)
Strainer/Butt: MLS50A / MLS50B
Snare Wire: MS20SN15S
Color: Caramel Olive Ash Burst (OCOB)

STAR RESERVE WALNUT/BUBINGA



Color: Gloss Claro Walnut -GCW

TBWS1465S

Shell: 5.5mm, 4ply Walnut + 2ply Bubinga + 1 outer ply Claro Walnut w/Maple Sound Focus Rings
Size: 14"x6.5"
Lug: MTL160
Hoop: Sound Arc Hoop (10 Hole)
Strainer/Butt: MLS50A / MLS50B
Snare Wire: MS20RL14C
Color: Gloss Claro Walnut (GCW)

STAR RESERVE HAMMERED COPPER



TCS1465H

Shell: 1.5mm Hammered Copper
Size: 14"x6.5"
Lug: MSL90SC
Hoop: Customized Brass Mighty Hoop (8 Hole)
Strainer/Butt: MLS50A / MLS50B
Snare Wire: MS20RL14C

STAR RESERVE STAVE JATOBA



Color: Oiled Natural Jatoba -OJT

TVJ147S

Shell: 10mm, 16pcs Stave Jatoba
Size: 14"x7"
Lug: MTL160
Hoop: Die-Cast Hoop (8 Hole)
Strainer/Butt: MLS50A / MLS50B
Snare Wire: MS20RL14C
Color: Oiled Natural Jatoba (OJT)

STAR RESERVE HAMMERED BRASS



TBRS1455H

Shell: 1.5mm Hand Hammered Brass
Size: 14"x5.5"
Lug: MSL90SC
Hoop: Customized Brass Mighty Hoop (8 hole)
Strainer/Butt: MLS50A / MLS50B
Snare Wire: MS20RL14C

STAR RESERVE HAMMERED ALUMINUM



TAS1465H

Shell: 3mm Hand Hammered Aluminum
Size: 14"x6.5"
Lug: MSL90SC
Hoop: Brass Sound Arc Hoop (8 hole)
Strainer/Butt: MLS50A / MLS50B
Snare Wire: MS20RL14C

STAR RESERVE STAVE ASH



Color: Oiled Amber Ash -OAA

TVA1465S

Shell: 10mm/20pcs Stave Ash Shell
Size: 14"x6.5"
Lug: MSL90SC
Hoop: Sound Arc Hoop (10 hole)
Strainer/Butt: MLS50A / MLS50B
Snare Wire: MS20RL14C
Color: Oiled Amber Ash (OAA)

STAR RESERVE SOLID JAPANESE CEDAR



Color: Burnt Oiled Cedar -BOC

TLJC146

Shell: 8mm Solid Japanese Cedar
Size: 14"x6"
Lug: MSL90SC
Hoop: Customized Brass Mighty Hoop (8 hole)
Strainer/Butt: MLS50A / MLS50B
Snare Wire: MS20SN14B
Color: Burnt Oiled Cedar (BOC)

MASTERCRAFT BELL BRASS



BB-156

Shell: 3mm Cast Bell Brass
Size: 14"x6.5"
Lug: Original Superstar Lug (6371N)
Hoop: Die-Cast Hoop (10 hole)
Strainer/Butt: Roller Action
Snare Wire: 18-strand Carbon Steel Long Snare Wires
Inside Muffler: One Touch Tone Control (6552N)

STARPHONIC MAPLE



Color: Satin Mappa Burl -STM

PMM146

Shell: 6mm, 6ply Maple + 1 Mappa Burl outer ply
Size: 14"x6"
Lug: Freedom Lug
Hoop: Grooved Hoop
Strainer/Butt: MLS50A / MLS50B
Snare Wire: MS20RL14C
Color: Satin Mappa Burl (STM)

STARPHONIC SPRUCE



Color: Satin Natural Spruce -SSC

PSP146E

Shell: 8mm, 9ply Spruce
Size: 14"x6"
Lug: Freedom Lug
Hoop: Grooved Hoop
Strainer/Butt: MLS50A / MLS50B
Snare Wire: MS20RL14C
Color: Satin Natural Spruce (SSC)

STARPHONIC BUBINGA



Color: Matte Natural Cordia -MNC

PBC146

Shell: 7mm, 8ply Bubinga + 1 Cordia outer ply
Size: 14"x6"
Lug: Freedom Lug
Hoop: Grooved Hoop
Strainer/Butt: MLS50A / MLS50B
Snare Wire: MS20RL14C
Color: Matte Natural Cordia (MNC)

STARPHONIC WALNUT



Color: Gloss Black Walnut Burl -GWB

PWB147

Shell: 6mm, 6ply American Black Walnut Shell + 1 outer ply Black Walnut Burl
Size: 14"x7"
Lug: Freedom Lug
Hoop: Grooved Hoop
Strainer/Butt: MLS50A / MLS50B
Snare Wire: MS20RL14C
Color: Gloss Black Walnut Burl (GWB)

STARPHONIC BRASS



PBR146

Shell: 1.2mm Brass
Size: 14"x6"
Lug: Freedom Lug
Hoop: Grooved Hoop
Strainer/Butt: MLS50A / MLS50B
Snare Wire: MS20RL14C

STARPHONIC BELL BRASS



PBB146

Shell: 3mm Bell Brass
Size: 14"x6"
Lug: Freedom Lug
Hoop: Grooved Hoop
Strainer/Butt: MLS50A / MLS50B
Snare Wire: MS20RL14C

STARPHONIC COPPER



PCP147

Shell: 1.2mm Copper
Size: 14"x7"
Lug: Freedom Lug
Hoop: Grooved Hoop
Strainer/Butt: MLS50A / MLS50B
Snare Wire: MS20RL14C

STARPHONIC ALUMINUM



PAL146
Shell: 1.2mm Seamless Aluminum
Size: 14"x6"
Lug: Freedom Lug
Hoop: Grooved Hoop
Strainer/Butt: MLS50A/MLS50B
Snare Wire: MS20RL14C

STARPHONIC STEEL



PST146
Shell: 1mm Steel
Size: 14"x6"
Lug: Freedom Lug
Hoop: Grooved Hoop
Strainer/Butt: MLS50A/MLS50B
Snare Wire: MS20RL14C

STARCLASSIC MAPLE LACQUER FINISH



MAS1455
Please refer to the Starclassic Maple Lacquer Finish drum kit page to see available sizes and finishes. Antique Maple (ATM) is also available.
Lug: MSL-SCT
Hoop: Die-Cast Hoop
Strainer/Butt: MLS50A/MLS50B
Snare Wire: 14"=MS20RL14C, 13"=MS20RL13C

Color: Antique Maple -ATM

STARCLASSIC WALNUT/BIRCH LACQUER FINISH



WBSS65
Please refer to the Starclassic Walnut/Birch Lacquer Finish drum kit page to see available sizes and finishes.
Lug: MSL-SCT
Hoop: Die-Cast Hoop
Strainer/Butt: MSL30A/MLS30B
Snare Wire: 14"=MS20RL14C, 13"=MS20RL13C

Color: Molten Brown Burst -MBR

STARCLASSIC PERFORMER LACQUER FINISH



MBSS65
Please refer to the Starclassic Performer Lacquer Finish drum kit page to see available sizes and finishes.
Lug: MSL-SCT
Hoop: Die-Cast Hoop
Strainer/Butt: MSL30A/MLS30B
Snare Wire: 14"=MS20RL14C, 13"=MS20RL13C

Color: Sky Blue Aurora -SKA

S.L.P. MOD BUBINGA



LBU127
Shell: 6.0mm, 9ply Bubinga
Size: 12"x7"
Lug: MSL-SCT
Hoop: 2.3mm Sound Arc Hoop (6 Hole) (Batter side) / 1.6mm Sound Arc Hoop (6 Hole) (Snare side)
Strainer/Butt: MSL30A / MLS30B
Snare Wire: MS20SN12S
Color: Satin Bubinga (SBG)

Color: Satin Bubinga -SBG

STARPHONIC STAINLESS STEEL



PSS146
Shell: 1mm Stainless Steel w/ R.S.E.
Size: 14"x6"
Lug: Freedom Lug
Hoop: Grooved Hoop
Strainer/Butt: MLS50A/MLS50B
Snare Wire: MS20RL14C

STARCLASSIC MAPLE EXOTIC FINISH



MES1465U
Please refer to the Starclassic Maple Exotic Finish drum kit page to see available sizes and finishes.
Lug: MSL-SCT
Hoop: Die-Cast Hoop
Strainer/Butt: MLS50A/MLS50B
Snare Wire: 14"=MS20RL14C, 13"=MS20RL13C

Color: Tobacco Sunburst Movingui -VTBV

STARCLASSIC MAPLE DURACOVER WRAP FINISH



MRS136
Please refer to the Starclassic Maple Duracover Wrap Finish drum kit page to see available sizes and finishes.
Lug: MSL-SCT
Hoop: Die-Cast Hoop
Strainer/Butt: MLS50A/MLS50B
Snare Wire: 14"=MS20RL14C, 13"=MS20RL13C

Color: Blue and White Oyster -BWO

STARCLASSIC WALNUT/BIRCH DURACOVER WRAP FINISH



WBRS65
Please refer to the Starclassic Walnut/Birch Duracover Wrap Finish drum kit page to see available sizes and finishes.
Lug: MSL-SCT
Hoop: Die-Cast Hoop
Strainer/Butt: MSL30A/MLS30B
Snare Wire: 14"=MS20RL14C, 13"=MS20RL13C

Color: Charcoal Onyx -CCO

S.L.P. G-BUBINGA



LGB146
Shell: 10mm, 11ply Bubinga + 1 outer ply Quilted Bubinga
Size: 14"x6"
Lug: MSL-SCTBN
Hoop: Steel Mighty Hoop (10 Hole)
Strainer/Butt: MSL50ABN / MLS50BBN
Snare Wire: MS20SN14S
Color: Natural Quilted Bubinga (NQB)

Color: Natural Quilted Bubinga -NQB

S.L.P. G-MAPLE



LGM146
Shell: 11mm, 12ply Maple + 1 outer ply Mappa Burl
Size: 14"x6"
Lug: MSL-SCTBN
Hoop: Steel Mighty Hoop (10 Hole)
Strainer/Butt: MSL50ABN / MLS50BBN
Snare Wire: MS20RL14C
Color: Kona Mappa Burl (KMB)

Color: Kona Mappa Burl -KMB

S.L.P. G-MAPLE



LGM137
Shell: 10mm, 11ply Maple + 1 outer ply Tamo Ash
Size: 13"x7"
Lug: MTL60
Hoop: Die-Cast Hoop (8 hole)
Strainer/Butt: MSL50A/MLS50B
Snare Wire: MS20SN13C
Color: Satin Tamo Ash (STA)

Color: Satin Tamo Ash -STA

S.L.P. DUO BIRCH



LBH1410L
Shell: 7mm, 7ply Birch
Size: 14"x10"
Lug: MSL-SCT
Hoop: Sound Arc Hoop (8 hole)
Strainer/Butt: MCS70A/MCS70B
Snare Wire: MS20R14S
Color: Transparent Mocha (TPM)
*MTB25E Brackets are equipped.
*MFLSL3P Legs are included.

Color: Transparent Mocha -TPM

S.L.P. CLASSIC MAPLE



LMP1455
Shell: 7mm, 8ply Maple
Size: 14"x5.5"
Lug: MTL50
Hoop: Sound Arc Hoop (10 hole)
Strainer/Butt: MSL50A/MLS50B
Snare Wire: MS20RL14C
Color: Super Maple (SMP)

Color: Super Maple -SMP

S.L.P. EXPRESSIVE HAMMERED STEEL



LST146H
Shell: 1.2mm Hammered Steel
Size: 14"x6"
Lug: MCHL5SBN
Hoop: 2.3mm Steel Mighty Hoop (10 hole)
Strainer/Butt: MSL30ABN/MLS30BBN
Snare Wire: MS20SN14S

S.L.P. BLACK BRASS



LBR1465
Shell: 1.5mm Brass
Size: 14"x6.5"
Lug: MSL-SCTBN
Hoop: Steel Mighty Hoop (10 hole)
Strainer/Butt: MSL30ABN/MLS30BBN
Snare Wire: MS42R14S

S.L.P. CLASSIC DRY ALUMINUM



LAL1455
Shell: 1.2mm Seamless Aluminum
Size: 14"x5.5"
Lug: MCHL5S
Hoop: Steel Mighty Hoop (8 hole)
Strainer/Butt: MSL30A/MLS30B
Snare Wire: MS20RL14C

S.L.P. G-WALNUT



LGW1465
Shell: 9mm, 10ply Walnut
Size: 14"x6.5"
Lug: MTL60
Hoop: Sound Arc Hoop (10 hole)
Strainer/Butt: MSL50A/MLS50B
Snare Wire: MS30R14S
Color: Matte Black Walnut (MBW)

Color: Matte Black Walnut -MBW

S.L.P. FAT SPRUCE



LSP146
Shell: 7mm, 10ply Spruce
Size: 14"x6"
Lug: MTL60
Hoop: Die-Cast Hoop (8 hole)
Strainer/Butt: MSL50A/MLS50B
Snare Wire: MS20RL14C
Color: Wild Satin Spruce (WSS), Turquoise (TUQ)

Color: Wild Satin Spruce -WSS

S.L.P. STUDIO MAPLE



LMP1465F
Shell: 5mm, 6ply Maple w/ Sound Focus Rings
Size: 14"x6.5"
Lug: MSL-SCT
Hoop: 100% Maple Wood Hoop (8 hole)
Strainer/Butt: MSL50A/MLS50B
Snare Wire: MS20SN14S
Color: Sienna (SEN)

Color: Sienna -SEN

S.L.P. DYNAMIC BRONZE



LBZ1445
Shell: 1.2mm Bronze in Aged Finish
Size: 14"x4.5"
Lug: MSL-SCPBN
Hoop: Die-Cast Hoop (8 hole)
Strainer/Butt: MSL30ABN/MLS30BBN
Snare Wire: MS20SN14C

S.L.P. BIG BLACK STEEL



LST148
Shell: 1mm Steel in Matte Black Finish
Size: 14"x8"
Lug: MSL35BN
Hoop: Steel Mighty Hoop (10 hole)
Strainer/Butt: MSL30ABN/MLS30BBN
Snare Wire: MS20SN14S

METALWORKS



BST1055MBK
Shell: 1mm Steel
Size: 10"x5.5"
Lug: MSL60SBK
Hoop: Triple Flanged Hoop (6 hole)
Strainer/Butt: MSL65ABK/MSL60BBK
Snare Wire: MS16R10S
*Tom bracket is equipped.

METALWORKS



BST134BK
 Shell: 1mm Steel
 Size: 13"x4"
 Lug: MSL-SCPBK
 Hoop: Triple Flanged Hoop (6 hole)
 Strainer/Butt: MCS70ABK/MCS70BBK
 Snare Wire: MS20R13S

METALWORKS



BST1455BK
 Shell: 1mm Steel
 Size: 14"x5.5"
 Lug: MSL60SBK
 Hoop: Triple Flanged Hoop (8 hole)
 Strainer/Butt: MUS65ABK/MUS60BBK
 Snare Wire: MS20R14S

METALWORKS



BST1465BK
 Shell: 1mm Steel
 Size: 14"x6.5"
 Lug: MSL60SBK
 Hoop: Triple Flanged Hoop (8 hole)
 Strainer/Butt: MUS65ABK/MUS60BBK
 Snare Wire: MS20R14S

METALWORKS EFFECT MINI-TYMP SNARE DRUMS



BST63MBK
 Shell: 1mm Steel
 Size: 6"x3"
 Lug: MSL80TBK
 Hoop: Triple Flanged Hoop (4 hole)
 Snare Wire: Mod Tone System w/ Snare Wire
 *Tom bracket is equipped.
 *MC69 single tom attachment is included.

METALWORKS EFFECT MINI-TYMP SNARE DRUMS



BST83MBK
 Shell: 1mm Steel
 Size: 8"x3"
 Lug: MSL80TBK
 Hoop: Triple Flanged Hoop (4 hole)
 Snare Wire: Mod Tone System w/ Snare Wire
 *Tom bracket is equipped.
 *MC69 single tom attachment is included.

METALWORKS EFFECT MINI-TYMP SNARE DRUMS



BST103MBK
 Shell: 1mm Steel
 Size: 10"x3"
 Lug: MSL80TBK
 Hoop: Triple Flanged Hoop (6 hole)
 Snare Wire: Mod Tone System w/ Snare Wire
 *Tom bracket is equipped.
 *MC69 single tom attachment is included.

METALWORKS EFFECT MINI-TYMP SNARE DRUMS



BST143MBK
 Shell: 1mm Steel
 Size: 14"x3"
 Lug: MSL80TBK
 Hoop: Triple Flanged Hoop (6 hole)
 Snare Wire: Mod Tone System w/ Snare Wire
 *Tom bracket is equipped.
 *MC69 single tom attachment is included.

WOODWORKS



WP1455BK
 Shell: 8mm, 8ply Poplar
 Size: 14"x5.5"
 Lug: MSL60SBK
 Hoop: Triple Flanged Hoop (8 hole)
 Strainer/Butt: MUS65ABK/MUS60BBK
 Snare Wire: MS20R14S
 Color: Natural ZebraWood Wrap (NZW), Black Oak Wrap (BOW)

Color: Black Oak Wrap (BOW)

WOODWORKS



WP1465BK
 Shell: 8mm, 8ply Poplar
 Size: 14"x6.5"
 Lug: MSL60SBK
 Hoop: Triple Flanged Hoop (8 hole)
 Strainer/Butt: MUS65ABK/MUS60BBK
 Snare Wire: MS20R14S
 Color: Natural ZebraWood Wrap (NZW), Black Oak Wrap (BOW)

Color: Natural ZebraWood Wrap (NZW)

WOODWORKS



WP148BK
 Shell: 8mm, 8ply Poplar
 Size: 14"x8"
 Lug: MSL60SBK
 Hoop: Triple Flanged Hoop (8 hole)
 Strainer/Butt: MUS65ABK/MUS60BBK
 Snare Wire: MS20R14S
 Color: Natural ZebraWood Wrap (NZW), Black Oak Wrap (BOW)

Color: Black Oak Wrap (BOW)

SIGNATURE PALETTE -CHARLIE BENANTE



CB1465
 Shell: 1.2mm Stainless Steel
 Size: 14"x6.5"
 Lug: MSL35BN
 Hoop: Die-Cast Hoop (10 hole)
 Strainer/Butt: MSL50ABN/MLS50BBN
 Snare Wire: MS20SN14S

SIGNATURE PALETTE -STEWART COPELAND



SC145
 Shell: 1.5mm Brass
 Size: 14"x5"
 Lug: MSL35
 Hoop: Die-Cast Hoop (10 hole, Batter side)/Steel Mighty Hoop (10 hole, Snare side)
 Strainer/Butt: MSL50A/MLS50B
 Snare Wire: MS20SN14S

SIGNATURE PALETTE -PETER ERSKINE



PE106M
 Shell: 10mm, 12pcs Stave Ash
 Size: 10"x6"
 Lug: MSL90SC
 Hoop: Die-Cast Hoop (6 Hole)
 Strainer/Butt: MSL50A / MLS50B
 Snare Wire: MS20SN10S
 Super Resonant Mounting System Equipped

SIGNATURE PALETTE -PETER ERSKINE



PE1445
 Shell: 6mm, 4ply Spruce + 2 inner ply Maple w/ Sound Focus Ring only for batter side (Same configuration : 6mm, 4ply Spruce + 2 inner ply Maple)
 Size: 14"x4.5"
 Lug: MTL145
 Hoop: 2.3mm Sound Arc Hoop (8 Hole)
 Strainer/Butt: MSL50A / MLS50B
 Snare Wire: MS20RL14C

SIGNATURE PALETTE -MIKE PORTNOY



MP125ST
 Shell: 1mm Steel (Hammered Matte Black)
 Size: 12"x5"
 Lug: MSL-SCT
 Hoop: Die-Cast Hoop (6 hole)
 Strainer/Butt: MCS100A/MCS70B
 Snare Wire: MS20SN12S

SIGNATURE PALETTE -MIKE PORTNOY



MP1455ST
 Shell: 1mm Steel (Hammered Matte Black)
 Size: 14"x5.5"
 Lug: MSL-SCT
 Hoop: Die-Cast Hoop (8 hole)
 Strainer/Butt: MCS100A/MCS70B
 Snare Wire: MS20SN14S

SIGNATURE PALETTE -MIKE PORTNOY



MP1455BU
 Shell: 8mm, 9ply Bubinga
 Size: 14"x5.5"
 Lug: MSL-SCT
 Hoop: Die-Cast Hoop (8 hole)
 Strainer/Butt: MCS100A/MCS70B
 Snare Wire: MS20SN14S

SIGNATURE PALETTE -SIMON PHILLIPS



SP1465
 Shell: 6.0mm, 8ply Mahogany w/ 6.0mm Sound Focus Rings
 Size: 14"x6.5"
 Lug: MSL90S
 Hoop: Customized Brass Mighty Hoop (8 hole)
 Strainer/Butt: MSL50A / MLS50B
 Snare Wire: 20-strand Carbon Steel Snare Wires

SIGNATURE PALETTE -JOHN TEMPESTA



JT147
 Shell: 2mm Brass
 Size: 14"x7"
 Lug: MSL-SCTBN
 Hoop: Die-Cast Hoop (10 hole)
 Strainer/Butt: MSL50ABN/MLS50BBN
 Snare Wire: MS42R14S

SIGNATURE PALETTE -LARS ULRICH



LU1465N
 Shell: 3mm Diamond Plate Steel
 Size: 14"x6.5"
 Lug: MSL35
 Hoop: Die-Cast Hoop (10 hole)
 Strainer/Butt: MSL50A/MLS50B
 Snare Wire: MS20SN14S

DRUM PEDALS

Our Iron Cobra pedals have long been praised for being smooth, reliable, and independently adjustable. Iron Cobra pedals are offered in the high end 900 series as well as the standard 600 and 200 models. Speed Cobra 910 and 310 drum pedals feature a longer footboard for a lighter, quicker feel. Our drum pedal range is designed to fit the needs of every drummer.

DYNA-SYNC SINGLE PEDAL



HPDS1

- Optimized Transmission Design
- Dual Linkage
- Slidable Cam
- Footboard Angle Adjustment
- Dyna Beater
- Swivel Spring Tight
- Speedo-Ring
- Oiles Bearing Hinge
- Para-Clamp II Pro
- Sync-Coil
- Hinge Guard Block
- Hardshell Carrying Case

DYNA-SYNC TWIN PEDAL



HPDS1TW

- Optimized Transmission Design
- Dual Linkage
- Slidable Cam
- Footboard Angle Adjustment
- Dyna Beater
- Swivel Spring Tight
- Speedo-Ring
- Oiles Bearing Hinge
- Para-Clamp II Pro
- Sync-Coil
- Hinge Guard Block
- Hardshell Carrying Case

DYNA-SYNC TWIN PEDAL



HPDS1TWL

- Left-Footed
- Optimized Transmission Design
- Dual Linkage
- Slidable Cam
- Footboard Angle Adjustment
- Dyna Beater
- Swivel Spring Tight
- Speedo-Ring
- Oiles Bearing Hinge
- Para-Clamp II Pro
- Sync-Coil
- Hinge Guard Block
- Hardshell Carrying Case

SPEED COBRA 910 SINGLE PEDAL



HP910LN

- Long Footboard
- Recessed Setting
- Rolling Glide LiteSprocket Cam
- Accu-Strike Cobra Beater
- Swivel Spring Tight
- Super Stabilizer Design
- Para-Clamp II Pro
- Cobra Coil
- Hinge Guard Block
- Hardshell Carrying Case

SPEED COBRA 910 TWIN PEDAL



HP910LWN

- Long Footboard
- Recessed Setting
- Rolling Glide LiteSprocket Cam
- Accu-Strike Cobra Beater
- Swivel Spring Tight
- Super Stabilizer Design
- Para-Clamp II Pro
- Cobra Coil
- Hinge Guard Block
- Hardshell Carrying Case

SPEED COBRA 910 TWIN PEDAL



HP910LWLN

- Left-Footed
- Long Footboard
- Recessed Setting
- Rolling Glide LiteSprocket Cam
- Accu-Strike Cobra Beater
- Swivel Spring Tight
- Super Stabilizer Design
- Para-Clamp II Pro
- Cobra Coil
- Hinge Guard Block
- Hardshell Carrying Case

IRON COBRA 900 SINGLE PEDAL -POWER GLIDE-



HP900PN

- Power Glide LiteSprocket Cam
- Power-Strike Cobra Beater
- Swivel Spring Tight
- Super Stabilizer Design
- Para-Clamp II Pro
- Cobra Coil
- Hinge Guard Block
- Hardshell Carrying Case

IRON COBRA 900 TWIN PEDAL -POWER GLIDE-



HP900PWN

- Power Glide LiteSprocket Cam
- Power-Strike Cobra Beater
- Swivel Spring Tight
- Super Stabilizer Design
- Para-Clamp II Pro
- Cobra Coil
- Hinge Guard Block
- Hardshell Carrying Case

IRON COBRA 900 TWIN PEDAL -POWER GLIDE-



HP900PWLN

- Left-Footed
- Power Glide LiteSprocket Cam
- Power-Strike Cobra Beater
- Swivel Spring Tight
- Super Stabilizer Design
- Para-Clamp II Pro
- Cobra Coil
- Hinge Guard Block
- Hardshell Carrying Case

IRON COBRA 900 SINGLE PEDAL -ROLLING GLIDE-



HP900RN

- Rolling Glide LiteSprocket Cam
- Power-Strike Cobra Beater
- Swivel Spring Tight
- Super Stabilizer Design
- Para-Clamp II Pro
- Cobra Coil
- Hinge Guard Block
- Hardshell Carrying Case

IRON COBRA 900 TWIN PEDAL -ROLLING GLIDE-



HP900RWN

- Rolling Glide LiteSprocket Cam
- Power-Strike Cobra Beater
- Swivel Spring Tight
- Super Stabilizer Design
- Para-Clamp II Pro
- Cobra Coil
- Hinge Guard Block
- Hardshell Carrying Case

IRON COBRA 600 SINGLE PEDAL -DUO GLIDE-



HP600D

- Duo Glide
- Double Chain Drive
- Speedo-Ring
- Para-Clamp
- Spring Tension Adjustment
- Beater Angle Adjustment
- Dual Sided Beater

IRON COBRA 600 TWIN PEDAL -DUO GLIDE-



HP600DTW

- Duo Glide
- Double Chain Drive
- Speedo-Ring
- Para-Clamp
- Spring Tension Adjustment
- Beater Angle Adjustment
- Dual Sided Beater

SPEED COBRA 310 SINGLE PEDAL



HP310L

- Long Footboard
- Recessed Setting
- Rolling Glide LiteSprocket
- Double Chain Drive
- Spring Tension Adjustment
- Beater Angle Adjustment
- Dual Sided Beater

SPEED COBRA 310 TWIN PEDAL



HP310LW

- Long Footboard
- Recessed Setting
- Rolling Glide LiteSprocket
- Double Chain Drive
- Spring Tension Adjustment
- Beater Angle Adjustment
- Dual Sided Beater

IRON COBRA 200 SINGLE PEDAL



HP200P

- Power Glide
- Spring Tension Adjustment
- Beater Angle Adjustment
- Dual Sided Beater

IRON COBRA 200 TWIN PEDAL



HP200PTW

- Power Glide
- Spring Tension Adjustment
- Beater Angle Adjustment
- Dual Sided Beater

IRON COBRA 200 TWIN PEDAL



HP200PTWL

- Left-Footed
- Power Glide
- Spring Tension Adjustment
- Beater Angle Adjustment
- Dual Sided Beater

STANDARD SINGLE PEDAL



HP30

- Power Glide
- Spring Tension Adjustment
- Beater Angle Adjustment
- Dual Sided Beater

STANDARD TWIN PEDAL



HP30TW

- Power Glide
- Spring Tension Adjustment
- Beater Angle Adjustment
- Dual Sided Beater

THE CLASSIC PEDAL



HP50

- Center Strike Height Adjust
- Easy Access Spring Adjustment
- The Classic Beater
- Smooth Surface Footboard
- Individual Adjustment of Beater & Footboard Angle
- Easy-Tight Hoop Clamp
- Compact Folding Design

MIRROR ROD



TMR1000

The Mirror Rod is a double pedal connecting rod designed to eliminate play and deliver an overwhelmingly smooth playing experience. By utilizing ball bearings, lightweight materials, a streamlined design, and concentrating the weight at the central axis, an extremely precise motion is achieved, eliminating pedal lag or play. An extreme ease of operation is achieved by a simplified pedal attachment and length adjustment design.

HI-HAT STANDS

In addition to bass drum pedals, we offer various hi-hat stands including our high end Dyna-Sync, Iron Cobra & Speed Cobra models as well as our standard Stage Master models.

IRON COBRA 600 HI-HAT STAND



HH605

- Spring Seat
- Swing Lock Clutch
- 6-way Tension Adjustment
- Swivel Foot
- Direct Pull Action
- Footboard Angle Adjustment
- Weight: 4.3kg (9.7lbs)
- Height Adjustment Range: 710mm-930mm (28" - 36 5/8")

SPEED COBRA 310 HI-HAT STAND



HH315D

- Dual Leg
- 28.6mm Diameter Base Section Tubing
- Security Clutch
- 6-way Tension Adjustment
- Swivel Foot
- Direct Pull Action
- Weight: 3.9kg (8.9lbs)
- Height Adjustment Range: 710mm-930mm (28" - 36 5/8")

IRON COBRA 200 HI-HAT STAND



HH205

- Double Braced Legs
- 5-way Tension Adjustment
- Swivel Foot
- Direct Pull Action
- Non-Loosening Tension Rod
- Toe Guard
- Security Clutch
- Weight: 3.8kg (8.6lbs)
- Height Adjustment Range: 670mm-930mm (26 3/8" - 36 5/8")

IRON COBRA 200 HI-HAT STAND



HH205S

- Single Braced Legs
- 5-way Tension Adjustment
- Swivel Foot
- Direct Pull Action
- Non-Loosening Tension Rod
- Toe Guard
- Security Clutch
- Weight: 3.1kg (6.8lbs)
- Height Adjustment Range: 670mm-930mm (26 3/8" - 36 5/8")

STAGE MASTER HI-HAT STAND



HH45WN

- Double Braced Legs
- Swivel Foot
- Direct Pull Action
- Non-Loosening Tension Rod
- Toe Guard
- Security Clutch
- Weight: 3.4kg (7.6lbs)
- Height Adjustment Range: 670mm-930mm (26 3/8" - 36 5/8")

THE CLASSIC HI-HAT STAND



HH55F

- Single Braced Flat Base Tripod Legs
- Individual Adjustment of Spring Tension & Footboard Angle
- Knurling on Base Pipe
- Memory Lock
- Weight: 2.3kg (5.1 lbs)
- Height Adjustment Range: 650mm-950mm (24 5/8" - 37 3/8")
- Storage size: 500mm (19 11/16") (upper section) / 600mm (23 5/8") (lower section)

DYNA-SYNC HI-HAT STAND



HHDS1

- Direct Drive Action
- Spring Damper for Reducing Noise
- Quick-Set Hi-Hat Clutch
- 6-way Tension Adjustment
- Footboard Angle Adjustment
- Bigger Rubber Feet w/Duo-Spike
- Weight: 5.2kg (11.7lbs)
- Height Adjustment Range: 745mm-960mm (29 3/8" - 37 3/4") (Standard Rod) / 745mm-810mm (29 3/8" - 31 7/8") (Short Rod)

SPEED COBRA 910 HI-HAT STAND - LEVER GLIDE



HH915D

- Spring Seat
- Quick-Set Hi-Hat Clutch
- 6-way Tension Adjustment
- Bigger Rubber Feet w/Duo-Spike
- Weight: 5.2kg (11.7lbs)
- Height Adjustment Range: 745mm-960mm (29 3/8" - 37 3/4") (Standard Rod) / 745mm-810mm (29 3/8" - 31 7/8") (Short Rod)

IRON COBRA 900 HI-HAT STAND -LEVER GLIDE



HH905D

- Spring Seat
- Quick-Set Hi-Hat Clutch
- 6-way Tension Adjustment
- Bigger Rubber Feet w/Duo-Spike
- Weight: 5.2kg (11.7lbs)
- Height Adjustment Range: 745mm-960mm (29 3/8" - 37 3/4") (Standard Rod) / 745mm-810mm (29 3/8" - 31 7/8") (Short Rod)

IRON COBRA 900 REMOTE HI-HAT STAND



HH905RH

- JAGWIRE™ Triple-Layered Ultra-Smooth Cable
- Quick-Set Hi-Hat Clutch
- Lever Glide
- 6-way Tension Adjustment
- MC66 Universal Clamp
- Ratchet Arm (Φ12mm, Arm Length: 200mm)
- Dual Leg
- Cable Holders (x 6)
- Carrying Bag
- Weight: 8.1kg (17lbs)

DRUM THRONES

Being comfortable on your drum set is one of the most important aspects of drumming, making the drum throne a vital yet often overlooked piece of equipment. Our ergonomic 1st Chair Drum Thrones have many original TAMA features to guarantee comfort, stability, and quick, easy setup.

1ST CHAIR ROUND RIDER XL DRUM THRONE -CLOTH TOP



HT850BC

Round Rider XL "Cloth Top" Seat
 -15" Diameter, 130mm (5 1/8") Thick Round Seat
 -HYDRAULIX
 -Seat Lock
 -Oversized Rubber Feet
 -Foot Life
 -Weight: 6.0kg (13.3lbs)
 -Height Adjustment Range: 515mm - 695mm (21 1/4" - 27 3/8")

1ST CHAIR ROUND RIDER XL DRUM THRONE



HT830R

Round Rider XL Seat
 -15" Diameter, 130mm (5 1/8") Thick Round Seat
 -1st Chair Height Adjustment
 -Seat Lock
 -Glide-Tite Grip Joint
 -Rocklok
 -Oversized Rubber Feet
 -Foot Life
 -Weight: 6.0kg (13.3lbs)
 -Height Adjustment Range: 515mm - 670mm (21 1/4" - 26 3/8")

1ST CHAIR ROUND RIDER XL DRUM THRONE



HT830B

Round Rider XL Seat
 -15" Diameter, 130mm (5 1/8") Thick Round Seat
 -1st Chair Height Adjustment
 -Seat Lock
 -Glide-Tite Grip Joint
 -Rocklok
 -Oversized Rubber Feet
 -Foot Life
 -Weight: 6.0kg (13.3lbs)
 -Height Adjustment Range: 515mm - 670mm (21 1/4" - 26 3/8")

1ST CHAIR ERGO-RIDER DRUM THRONE -CLOTH TOP



HT750BC

Ergo-Rider "Cloth Top" Seat
 -HYDRAULIX
 -Seat Lock
 -Oversized Rubber Feet
 -Foot Life
 -Weight: 6.1kg (13.7lbs)
 -Height Adjustment Range: 505mm - 685mm (19 7/8" - 27")

1ST CHAIR ERGO-RIDER DRUM THRONE



HT730B

Ergo-Rider Seat
 -1st Chair Height Adjustment
 -Seat Lock
 -Glide-Tite Grip Joint
 -Rocklok
 -Oversized Rubber Feet
 -Foot Life
 -Weight: 6.1kg (13.7lbs)
 -Height Adjustment Range: 505mm - 660mm (19 7/8" - 26")

1ST CHAIR ERGO-RIDER DRUM THRONE -QUARTET



HT741B

Ergo-Rider Seat
 -1st Chair Height Adjustment
 -Seat Lock
 -Backrest
 -Glide-Tite Grip Joint
 -Rocklok
 -Oversized Rubber Feet
 -Foot Life
 -Weight: 9.4kg (20.1lbs)
 -Height Adjustment Range: 515mm - 665mm (20 1/4" - 26 3/6")

1ST CHAIR GLIDE RIDER DRUM THRONE -CLOTH TOP



HT550BCN

Glide Rider "Cloth Top" Seat
 -HYDRAULIX
 -Seat Lock
 -Glide-Tite Grip Joint
 -Oversized Rubber Feet
 -Foot Life
 -Weight: 5.9kg (13lbs)
 -Height Adjustment Range: 470mm - 650mm (18 1/2" - 24 5/8")

1ST CHAIR GLIDE RIDER DRUM THRONE -CLOTH TOP



HT530BCN

Glide Rider "Cloth Top" Seat
 -1st Chair Height Adjustment
 -Seat Lock
 -Glide-Tite Grip Joint
 -Rocklok
 -Oversized Rubber Feet
 -Foot Life
 -Weight: 5.9kg (13lbs)
 -Height Adjustment Range: 470mm - 675mm (18 1/2" - 26 1/2")

1ST CHAIR WIDE RIDER DRUM THRONE -CLOTH TOP



HT530BC

Wide Rider "Cloth Top" Seat
 -1st Chair Height Adjustment
 -Seat Lock
 -Glide-Tite Grip Joint
 -Rocklok
 -Oversized Rubber Feet
 -Foot Life
 -Weight: 6.0kg (13.3lbs)
 -Height Adjustment Range: 485mm - 640mm (19" - 25 3/16")

1ST CHAIR WIDE RIDER DRUM THRONE



HT530B

Wide Rider Seat
 -1st Chair Height Adjustment
 -Seat Lock
 -Glide-Tite Grip Joint
 -Rocklok
 -Oversized Rubber Feet
 -Foot Life
 -Weight: 6.0kg (13.3lbs)
 -Height Adjustment Range: 485mm - 640mm (19" - 25 3/16")

1ST CHAIR ROUND RIDER DRUM THRONE -CLOTH TOP



HT430BC

Round Rider "Cloth Top" Seat
 -14" Diameter, 120mm (4 3/4") Thick Round Seat
 -1st Chair Height Adjustment
 -Seat Link
 -Rocklok
 -Foot Life
 -Weight: 5.3kg (11.1lbs)
 -Height Adjustment Range: 485mm - 655mm (19" - 25 3/4")

1ST CHAIR ROUND RIDER DRUM THRONE



HT430B

Round Rider Seat
 -14" Diameter, 120mm (4 3/4") Thick Round Seat
 -1st Chair Height Adjustment
 -Seat Link
 -Rocklok
 -Foot Life
 -Weight: 5.3kg (11.1lbs)
 -Height Adjustment Range: 485mm - 655mm (19" - 25 3/4")

1ST CHAIR SADDLE-TYPE DRUM THRONE



HT250

Saddle-Type Seat
 -1st Chair Height Adjustment
 -Glide-Tite Grip Joint
 -Rocklok
 -Foot Life
 -Weight: 4.05kg (8.9lbs)
 -Height Adjustment Range: 425mm - 625mm (16 3/4" - 24 1/2")

1ST CHAIR ROUNDED TYPE DRUM THRONE



HT230

Rounded Seat
 -1st Chair Height Adjustment
 -Glide-Tite Grip Joint
 -Rocklok
 -Foot Life
 -Weight: 4.0kg (8.8lbs)
 -Height Adjustment Range: 460mm - 660mm (18" - 26")

1ST CHAIR LOW PROFILE ROUNDED TYPE DRUM THRONE



HT230LOW

Rounded Seat
 -1st Chair Height Adjustment
 -Glide-Tite Grip Joint
 -Rocklok
 -Foot Life
 -Weight: 3.6kg (8lbs)
 -Height Adjustment Range: 374mm - 519mm (15" - 20 1/2")

STANDARD DRUM THRONE



HT130

-13" Diameter, 90mm (3 1/2") Thick Round Seat
 -Double Braced Legs
 -Weight: 3.4kg (7.7lbs)
 -Height Adjustment Range: 445mm - 620mm (17 1/2" - 24 7/16")

SNARE STANDS

Our STAR snare stand has several unique features which provide the ultimate solution for a flexible and stable snare drum setup. Our Roadpro stands now have greater stability, in addition to Quick-Set universal tilters.

STAR HARDWARE SNARE STAND



HS100W

- For 12" to 15" Diameter Snare Drums
- 28.6mm Diameter Base Section Tubing
- Cradle-Hold Snare Basket
- Glide-Tite Grip Joint
- True-Sound Insulation Mute
- Oversized Rubber Feet with Retractable Spike
- Weight: 3.9kg (8.9lbs)
- Height Adjustment Range: 400mm - 600mm (15 3/4" - 23 5/8")

ROADPRO SNARE STAND



HS800W

- For 12" to 15" Diameter Snare Drums
- 28.6mm Diameter Base Section Tubing
- Omni-Ball Tilter
- Swiveling Basket
- Glide-Tite Grip Joint
- Double Braced Legs
- Weight: 3.4kg (7.7lbs)
- Height Adjustment Range: 495mm - 665mm (19 1/2" - 26 3/8")

ROADPRO SNARE STAND



HS80W

- For 12" to 15" Diameter Snare Drums
- 28.6mm Diameter Base Section Tubing
- Quick-Set Tilter
- Swiveling Basket
- Glide-Tite Grip Joint
- Double Braced Legs
- Weight: 3.2kg (7lbs)
- Height Adjustment Range: 495mm - 640mm (19 1/2" - 25 3/16")

ROADPRO SNARE STAND



HS80PW

- For 10" to 12" Diameter Snare Drums
- 28.6mm Diameter Base Section Tubing
- Quick-Set Tilter
- Swiveling Basket
- Glide-Tite Grip Joint
- Double Braced Legs
- Weight: 3.2kg (7lbs)
- Height Adjustment Range: 465mm - 610mm (18 5/16" - 24")

ROADPRO SNARE STAND



HS80LOW

- For 12" to 15" Diameter Snare Drums
- 28.6mm Diameter Base Section Tubing
- Low Position Setting Basket
- Quick-Set Tilter
- Glide-Tite Grip Joint
- Double Braced Legs
- Weight: 3.3kg (7.4lbs)
- Height Adjustment Range: 385mm - 530mm (15 3/16" - 20 7/8")

60 SERIES SNARE STAND



HS60W

- For 12" to 15" Diameter Snare Drums
- 25.4mm Diameter Base Section Tubing
- Quick-Set Tilter
- Swiveling Basket
- Double Braced Legs
- Weight: 2.6kg (5.1lbs)
- Height Adjustment Range: 470mm - 600mm (18 1/2" - 23 5/8")

STAGE MASTER SNARE STAND



HS40WN

- For 12" to 15" Diameter Snare Drums
- 25.4mm Diameter Base Section Tubing
- Universal Gearless Tilter
- Swiveling Basket
- Double Braced Legs
- Weight: 2.6kg (5.11lbs)
- Height Adjustment Range: 470mm - 630mm (18 1/2" - 24 13/16")

STAGE MASTER SNARE STAND



HS40PWN

- For 10" to 12" Diameter Snare Drums
- 25.4mm Diameter Base Section Tubing
- Universal Gearless Tilter
- Swiveling Basket
- Double Braced Legs
- Weight: 2.6kg (5.11lbs)
- Height Adjustment Range: 470mm - 630mm (18 1/2" - 24 13/16")

STAGE MASTER SNARE STAND



HS40SN

- For 12" to 15" Diameter Snare Drums
- 25.4mm Diameter Base Section Tubing
- Universal Gearless Tilter
- Swiveling Basket
- Single Braced Legs
- Weight: 2.5kg (5.8lbs)
- Height Adjustment Range: 470mm - 630mm (18 1/2" - 24 13/16")

STAGE MASTER SNARE STAND



HS40LOWN

- For 12" to 15" Diameter Snare Drums
- 25.4mm Diameter Base Section Tubing
- Low Position Setting Basket
- Universal Gearless Tilter
- Double Braced Legs
- Weight: 2.7kg (5.15lbs)
- Height Adjustment Range: 370mm - 530mm (14 9/16" - 20 7/8")

THE CLASSIC SNARE STAND



HS50S

- For 12" to 15" Diameter Snare Drums
- 19.1mm Diameter Base Section Tubing
- Single Braced Tripod Legs
- Classic Style Basket
- Double Braced Arms
- Gearless Tilter
- Memory Lock
- Weight: 1.7kg (3.11lbs)
- Height Adjustment Range: 390mm-580mm (15 3/8" - 22 7/8")
- Storage size: 600mm (23 5/8")

CYMBAL STANDS

The TAMA STAR Hardware cymbal stand is incredibly flexible with several groundbreaking adjustment features. The Roadpro cymbal stands benefit from greater stability, and include the same great Quick-Set Tilter and Quick-Set Cymbal Mates.

STAR HARDWARE CYMBAL STAND



HC103BW

- 28.6mm Diameter Base Section Tubing
- Orbital Quick-Tite Cymbal/Boom Tilter
- Glide-Tite Grip Joint
- True-Sound Insulation Mute
- Ring-True Cymbal Felt
- Boom Arm Length: 450mm (17 3/4")
- Weight: 6.1kg (13.7lbs)
- Height Adjustment Range: 890mm - 2,090mm (35" - 82 1/4")

ROADPRO CYMBAL STAND



HC84BW

- 28.6mm Diameter Base Section Tubing
- Quick-Set Tilter
- Quick-Set Cymbal Mate
- Boom/Straight Convertible Tilter
- Glide-Tite Grip Joint
- Detachable Counter Weight
- Boom Arm Length: 688mm (27 3/32")
- Weight: 6.2kg (13.10lbs)
- Height Adjustment Range: 820mm - 2,200mm (32 1/4" - 86 5/8")

ROADPRO CYMBAL STAND



HC83BW

- 28.6mm Diameter Base Section Tubing
- Quick-Set Tilter
- Quick-Set Cymbal Mate
- Boom/Straight Convertible Tilter
- Glide-Tite Grip Joint
- Double Braced Legs
- Boom Arm Length: 450mm (17 3/4")
- Weight: 5.0kg (11lbs)
- Height Adjustment Range: 820mm - 2,100mm (32 1/4" - 82 5/8")

ROADPRO CYMBAL STAND



HC82W

- 28.6mm Diameter Base Section Tubing
- Quick-Set Tilter
- Quick-Set Cymbal Mate
- Glide-Tite Grip Joint
- Double Braced Legs
- Weight: 4.2kg (9.4lbs)
- Height Adjustment Range: 740mm - 1,610mm (29 1/8" - 72 7/8")

ROADPRO LIGHT CYMBAL STAND



HC83BLS

- 25.4mm Diameter Base Section Tubing
- Quick-Set Tilter
- Quick-Set Cymbal Mate
- Boom/Straight Convertible Tilter
- Glide-Tite Grip Joint
- Single Braced Legs
- Boom Arm Length: 400mm (15 3/4")
- Weight: 3.8kg (8.6lbs)
- Height Adjustment Range: 790mm - 1,850mm (31 1/8" - 72 7/8")

ROADPRO LIGHT CYMBAL STAND



HC82LS

- 25.4mm Diameter Base Section Tubing
- Quick-Set Tilter
- Quick-Set Cymbal Mate
- Glide-Tite Grip Joint
- Single Braced Legs
- Weight: 3.1kg (6.13lbs)
- Height Adjustment Range: 710mm - 1,410mm (28" - 55 1/2")

60 SERIES CYMBAL STAND



HC63BW

- 25.4mm Diameter Base Section Tubing
- Quick-Set Tilter
- Boom/Straight Convertible Tilter
- Double Braced Legs
- Boom Arm Length: 400mm (15 3/4")
- Weight: 3.9kg (8.9lbs)
- Height Adjustment Range: 850mm - 2,010mm (33 1/2" - 79 1/8")

STAGE MASTER CYMBAL STAND



HC43BWN

- 25.4mm Diameter Base Section Tubing
- Fine Gear Tilter
- Quick-Set Cymbal Mate
- Boom/Straight Convertible Tilter
- Double Braced Legs
- Boom Arm Length: 400mm (15 3/4")
- Weight: 3.4kg (7.5lbs)
- Height Adjustment Range: 760mm - 1,800mm (30" - 70 13/16")

STAGE MASTER CYMBAL STAND



HC43BSN

- 25.4mm Diameter Base Section Tubing
- Fine Gear Tilter
- Quick-Set Cymbal Mate
- Boom/Straight Convertible Tilter
- Single Braced Legs
- Boom Arm Length: 400mm (15 3/4")
- Weight: 3.4kg (7.7lbs)
- Height Adjustment Range: 760mm - 1,800mm (30" - 70 13/16")

STAGE MASTER CYMBAL STAND



HC42WN

- 25.4mm Diameter Base Section Tubing
- Fine Gear Tilter
- Quick-Set Cymbal Mate
- Double Braced Legs
- Weight: 2.9kg (6.6lbs)
- Height Adjustment Range: 690mm - 1,420mm (27 1/8" - 55 15/16")

STAGE MASTER CYMBAL STAND



HC42SN

- 25.4mm Diameter Base Section Tubing
- Fine Gear Tilter
- Quick-Set Cymbal Mate
- Single Braced Legs
- Weight: 2.7kg (5.15lbs)
- Height Adjustment Range: 690mm - 1,420mm (27 1/8" - 55 15/16")

THE CLASSIC CYMBAL STAND



HC52F

- 19.1mm Diameter Base Section Tubing
- Flat Base Leg Design
- 9mm Diameter Solid Upper Portion
- Fine Gear Tilter
- Compact Folding Design (580mm 22 27/32")
- Weight: 1.48kg (3.2lbs)
- Height Adjustment Range: 590mm - 1,300mm (23 1/4" - 51 3/16")

TOM STANDS & TOM HOLDERS

TAMA's tom stands and tom holders feature our original Omni-Ball system which allows each tom to be held securely in place. You can position the drum at virtually any angle simply by loosening one T-nut.

STAR HARDWARE COMBINATION STAND



HTC107W

- 28.6mm Diameter Base Section Tubing
- Swivel-Wing Tom Holder
- Orbital Quick-Tite Cymbal Tilter
- Orbital Quick-Tite Boom Tilter
- Glide-Tite Grip Joint
- True-Sound Insulation Mute
- Ring-True Cymbal Felt
- Boom Arm Length: 300mm (11 3/4")
- Weight: 7.2kg (15.13lbs)

STAR HARDWARE DOUBLE TOM STAND



HTW109W

- 28.6mm Diameter Base Section Tubing
- Swivel-Wing Tom Holder
- Stilt System
- Glide-Tite Grip Joint
- Extra Heavy Double Braced Legs
- Weight: 6.0kg (13lbs)
- Height Adjustment Range: 750mm-1,170mm (29 1/2" - 46")

STAR HARDWARE SINGLE TOM STAND



HTS108W

- For up to 10" Depth Tom Tom
- 28.6mm Diameter Base Section Tubing
- Omni-Ball Tilter
- Glide-Tite Grip Joint
- True-Sound Insulation Mute
- Extra Heavy Double Braced Legs
- Oversized Rubber Feet with Retractable Spike
- Weight: 4.3kg (9.7lbs)
- Height Adjustment Range: 740mm - 1,020mm (29 1/8" - 40 1/8")

ROADPRO COMBINATION STAND



HTC807W

- 28.6mm Diameter Base Section Tubing
- Omni-Ball Tom Angle Adjustment / Movable Tom Positioning
- Quick-Set Tilter
- Quick-Set Cymbal Mate
- Glide-Tite Grip Joint
- Double Braced Legs
- Boom Arm Length: 300mm (11 3/4")
- Weight: 5.4kg (11.14lbs)

ROADPRO COMBINATION STAND



HTC87W

- 28.6mm Diameter Base Section Tubing
- Omni-Ball Tom Angle Adjustment
- Quick-Set Tilter
- Quick-Set Cymbal Mate
- Glide-Tite Grip Joint
- Double Braced Legs
- Boom Arm Length: 300mm (11 3/4")
- Weight: 5.5kg (12.2lbs)

ROADPRO DOUBLE TOM STAND



HTW839W

- 28.6mm Diameter Base Section Tubing
- Omni-Ball Tom Angle Adjustment
- Stilt System
- Glide-Tite Grip Joint
- Double Braced Legs
- Weight: 5.0kg (11lbs)
- Height Adjustment Range: 790-1,270mm (31 1/8" - 50")

ROADPRO DOUBLE TOM STAND



HTW849W

- 28.6mm Diameter Base Section Tubing
- Omni-Ball Tom Angle Adjustment
- Glide-Tite Grip Joint
- Double Braced Legs
- Low Profile Tetrapod
- Weight: 5.1kg (11.3lbs)
- Height Adjustment Range: 550-800mm (21 5/8" - 31 1/2")

ROADPRO SINGLE TOM STAND



HTS88W

- 28.6mm Diameter Base Section Tubing
- Omni-Ball Tom Angle Adjustment
- Glide-Tite Grip Joint
- Double Braced Legs
- Height Adjustment Range: 760mm-1,240mm (30" - 49")
- Weight: 4.2kg (9.25lbs)

STAGE MASTER DOUBLE TOM STAND



HTW49WN

- 25.4mm Diameter Base Section Tubing
- Omni-Ball Tom Angle Adjustment
- Double Braced Legs
- Weight: 3.6kg (7.14lbs)
- Height Adjustment Range: 770-1,200mm (30 5/16" - 47 1/4")

THE CLASSIC TOM STAND



HTS58F

- For 10" to 14" Diameter Drums
- 19.1mm Diameter Base Section Tubing
- Flat Base Leg Design
- Classic Style Basket
- Memory Lock
- Weight: 1.8kg (3.15lbs)
- Height Adjustment Range: 565mm - 820mm (22 1/4" - 32 1/4")
- Storage size: 600mm (23 5/8") (upper section) / 410mm (16 1/8") (lower section)

DOUBLE TOM HOLDER



MTH1000

- 25.4mm Diameter Bass Section Tubing
- Swivel-Wing Tom Holder

MTH1000 (chrome)
MTH1000BN (black nickel)
MTH1000U (smoked black nickel)

DOUBLE TOM HOLDER



MTH800

- 25.4mm Diameter Tubing

DOUBLE TOM HOLDER



MTH600

- 25.4mm Diameter Tubing

MTH600 (chrome)
MTH600BN (black nickel)

SINGLE TOM HOLDER



MTH1000S

- 25.4mm Diameter Bass Section Tubing
- Swivel-Wing Tom Holder

MTH1000S (chrome)
MTH1000SBN (black nickel)
MTH1000SU (smoked black nickel)

SINGLE TOM HOLDER



MTH900BS

- 25.4mm Diameter Bass Section Tubing

SINGLE TOM HOLDER



MTH900BM

- 25.4mm Diameter Tubing

SINGLE TOM HOLDER



MTH800S

- 25.4mm Diameter Tubing

ROADPRO ELECTRONIC PAD STAND



HPS80W

- Glide-Tite Grip Joint
- Double Braced Tripod Base
- Weight: 3.7kg
- Height: 520mm - 1,020mm (20 1/2" - 40 1/8")

HARDWARE KITS

We offer various hardware kit packages to complement any drum sets.

IRON COBRA 900 HARDWARE KIT



HG5WN

- HS800W Roadpro Snare Stand
- HC83BW Roadpro Boom Cymbal Stands (x2)
- HH905D Iron Cobra Hi-hat Stand
- HP900PN Iron Cobra Power Glide Single Pedal

IRON COBRA 600 HARDWARE KIT



HV5WN

- HS80W Roadpro Snare Stand
- HC83BW Roadpro Boom Cymbal Stands (x2)
- HH605 Iron Cobra 600 Hi-hat Stand
- HP600D Iron Cobra 600 Single Pedal

IRON COBRA 200 HARDWARE KIT



HB5W

- HS60W Snare Stand
- HC63BW Boom Cymbal Stands (x2)
- HH205 Iron Cobra 200 Hi-hat Stand
- HP200P Iron Cobra 200 Single Pedal

STAGE MASTER HARDWARE KIT



SM5W

- HS40WN Stage Master Snare Stand
- HC43BWN Stage Master Boom Cymbal Stands (x2)
- HH205 Iron Cobra 200 Hi-hat Stand
- HP200P Iron Cobra 200 Single Pedal

THE CLASSIC STAND HARDWARE KIT



HC4FB

- HS50S Snare Stand
- HC52F Straight Cymbal Stands (x2)
- HH55F Hi-Hat Stand
- SBH01 Hardware Bag

IRON COBRA 200 BUNDLE WITH 1st CHAIR THRONE



HED3R

- HP200P Iron Cobra 200 Single Pedal
- HT230 1st Chair Drum Throne (Round seat)
- HH205S Iron Cobra 200 Hi-hat Stand

IRON COBRA 200 BUNDLE WITH 1st CHAIR THRONE



HED3G

- HP200P Iron Cobra 200 Single Pedal
- HT250 1st Chair Drum Throne (Saddle seat)
- HH205S Iron Cobra 200 Hi-hat Stand

IRON COBRA 200 BUNDLE WITH 1st CHAIR THRONE



HED2G

- HP200P Iron Cobra 200 Single Pedal
- HT250 1st Chair Drum Throne (Saddle seat)

ROADPRO BOOM STAND 2PCS PACK



HC83BW2

-HC83BW Roadpro Boom Cymbal Stands (x2)

STAGE MASTER BOOM STAND 2PCS PACK



HC43BWN2

-HC43BWN Stage Master Boom Cymbal Stands (x2)

THE CLASSIC STAND 2PCS PACK



HC52FX2

-HC52FX Straight Cymbal Stands (x2)

POWER TOWER SYSTEM

TAMA's Power Tower System allows you to maintain the same precise set-up time after time. It utilizes 38.1mm stainless round pipes which allow for drums and hardware to be set-up at any angle quickly and easily.

POWER TOWER SYSTEM BASIC UNIT



PMD1100M

- 1100mm Curved Pipe x 1pc
- 850mm Straight Pipe w/19.1mm diameter Joint x 2pc
- 40mm x 20mm x 450mm Square Pipe x 2pc
- Leg Joint Bracket x 2pc
- Rubber Foot x 4pc
- Cross Joint Bracket (J30TS) x 2pc
- Multi Holder (J34T) x 2pc
- Memory Lock (A13S) x 4pc

POWER TOWER SYSTEM ADDITIONAL UNIT



PMD1100A

- 1100mm Curved Pipe x 1pc
- 850mm Straight Pipe w/19.1mm diameter Joint x 1pc
- 40mm x 20mm x 450mm Square Pipe x 1pc
- Leg Joint Bracket x 1pc
- Rubber Foot x 2pc
- Cross Joint Bracket (J30TS) x 2pc
- Multi Holder (J34T) x 1pc
- Memory Lock (A13S) x 3pc

POWER TOWER SYSTEM ADDITIONAL UNIT



PMD900A

- 900mm Curved Pipe x 1pc
- 850mm Straight Pipe w/19.1mm diameter Joint x 1pc
- 40mm x 20mm x 450mm Square Pipe x 1pc
- Leg Joint Bracket x 1pc
- Rubber Foot x 2pc
- Cross Joint Bracket (J30TS) x 2pc
- Multi Holder (J34T) x 1pc
- Memory Lock (A13S) x 3pc

CROSS JOINT BRACKET



J30TS

90 degree perpendicular pipe clamp that allows horizontal and vertical pipes to be set at an equal height.

MULTI HOLDER



J34T

Rack mount for L-rods, tom or cymbal holders. Fits pipes from 10.5mm to 28.6mm in diameter.

MEMORY LOCK



A13S

Memory clamp designed specifically for the Power Tower System.

SINGLE TOM HOLDER



MTH900BS

A single tom holder with 25.4mm diameter base tube.

CLAMPS AND ATTACHMENTS

Back in the 1970's TAMA's original introduction of the multi-clamp was a real revolution in the complex instrument we know as the drum kit. Today, multi-clamps are standard equipment in drums of all brands.

UNIVERSAL CLAMP



MC66

One side can hold pipes with diameters from 15.9mm to 28.6mm, while the other side is a ratchet holder that can hold a rod from 9mm to 12mm in diameter at various angles. An excellent clamp for adding an array of new set-up possibilities.

UNIVERSAL CLAMP



MC67

The heavier duty version of the MC66. One side holds pipes with diameters from 15.9mm to 28.6mm, while the other side is a ratchet holder that can hold a 12mm to 25.4 mm diameter rod or pipe at various angles.

UNIVERSAL CLAMP



MC56

This clamp can be attached to an existing stand pipe that is 15.9mm to 28.6mm in diameter. By attaching a L-Rod or cymbal boom arm that is 9mm to 12mm in diameter, you can easily add a cowbell, woodblock, or cymbal to your drum kit.

MULTI-CLAMP



MC61

A basic clamp for connecting stands with pipes from 15.9mm to 28.6mm in diameter with any attachment having a 19.1mm diameter pipe.

MULTI-CLAMP



MC62

A double multi-clamp for connecting two pipes from 15.9mm to 28.6mm in diameter. Both sides feature the FastClamp Easy Set-Up System.

COMPACT CLAMP



MC7

Same function as the MC5, but with even greater flexibility. The ratchet holder section can hold any diameter tube from 12mm to 25.4mm.

HOOP GRIP



MC8

The Hoop Grip is a simple tool that allows you to add cymbals or other accessories to your drum kit to expand your setup and customize your sound.

-available on Steel Hoops and Die-Cast Hoops.
*NOT available on Wood Hoops.

HOOP GRIP FOR BASS DRUM



MC9

The MC9 Hoop Grip for bass drum is a simple clamp. However, when combined with an L-Rod or Z-Rod, you can set splash cymbal or various percussion items on the bass drum.

Z-ROD FOR COWBELL



ZCB

Z-rod for mounting cowbell or other percussion instruments and accessories (9mm diameter)

Z-ROD FOR SPLASH CYMBAL -LONG



ZCYEL

Z-rod for mounting lightweight cymbals (10.5mm diameter)

Details:
- Quick-set cymbal mate

Z-ROD FOR SPLASH CYMBAL -SHORT



ZCYE

Z-rod for mounting lightweight cymbals (10.5mm diameter)

Details:
- Quick-set cymbal mate

HOOP GRIP & ACCESSORY MOUNT ARM



MC8HCA20

Hoop Grip (MC8) & Accessory Mount Arm bundle package

CLOSED HI-HAT ATTACHMENT



MXA43

This closed hi-hat attachment utilizes a specially designed screw clutch, allowing for quick, easy, and precise adjustments. The space between the hi-hat cymbals can be adjusted by rotating the screw clutch clockwise or counterclockwise.

CLOSED HI-HAT ATTACHMENT



MXA53

This closed hi-hat attachment that allows for two different settings by turning a lever. Attachable to stands from 15.9mm to 28.6mm in diameter. Great for double bass or double pedal players.

CLOSED HI-HAT ATTACHMENT



MXA73N

The tension adjustment knob makes it possible to finely adjust the degree of opening of the hi-hat cymbals. In addition, the angle of the bottom cymbal is also adjustable.

- Quick-set hi-hat clutch
- Quick-set tilter

ELECTRONIC PAD HOLDER



MPH63

The MPH63 is a Fast-Clamp attachment for an electronic pad. Combining TAMA's MC66 universal clamp and the electronic pad stand boom arm, you can attach an electronic pad to any stand that has a 15.9mm to 28.6mm diameter pipe.

L-ROD FOR TOM TOM



LLT

L-rod for mounting toms (10.5mm diameter).

L-ROD FOR COWBELL



LCB

L-rod for mounting different hand percussion instruments and accessories. The 9mm diameter rod fits most popular percussion instruments designed for attachment to a 3/8" rod.

L-ROD FOR CYMBAL



LCYE

L-rod for mounting lightweight cymbals.

Details:

- Quick-set cymbal mate

L-ROD FOR HI-HAT CYMBAL



LHH

L-Rod for Hi-hat cymbals.

Details:

- Screw-Type Hi-hat clutch

HAT STACK



CSH5

- Easily attach a small cymbal to hi-hat rod measuring up to 7mm in diameter
- Compact size and lightweight for easy transport and storage - 25mm (1") diameter x 40mm (1.5") height
- Ability to adjust cymbal sustain

CYMBAL STACKER



CSA15

The CSA15 is a straight-forward cymbal stacker useful for adding small cymbals to your setup using the M8 threaded cymbal rod.

CYMBAL STACKER



CSA25

The CSA25 allows positioning of a small cymbal on the M8 threaded cymbal rod, as well as independent angle adjustment.

BOOM ARM



MCB30EN

MCB30EN can be used in combination with a ratchet arm or the MC66 universal clamp is available.

Details:

- 300mm (11 3/4") length
- Quick-set tilter
- Quick-set cymbal mate

BOOM ARM



MCB45EN

MCB45EN can be used in combination with a ratchet arm or the MC66 universal clamp is available.

Details:

- 450mm (17 3/4") length
- Quick-set tilter
- Quick-set cymbal mate

CYMBAL HOLDER



CACLJ

Bass Drum Mounted Cymbal Holder features telescoping arm & fine gear tilter, which allow you to adjust the angle and height of the cymbal as you like in smaller spaces.

CYMBAL HOLDER



CA30EN

- 300mm (11 3/4") length
- Quick-set tilter
- Quick-set cymbal mate

CYMBAL HOLDER



CA45EN

- 450mm (17 3/4") length
- Quick-set tilter
- Quick-set cymbal mate

CYMBAL ATTACHMENT



CCA30

The assortment of boom cymbal holder and MC61 multi-clamp. By connecting to stands from 15.9mm to 28.6mm in diameter, you can add any cymbal easily.

CYMBAL ATTACHMENT



MCA53

The MCA53 is a simplified attachment based on the functionality of the MCA63EN. Add cymbals by securing this attachment to stands from 15.9mm to 28.6mm in diameter.

CYMBAL ATTACHMENT



MCA63EN

Combines the MC66 universal clamp and the MCB30EN boom arm. Works perfectly for adding cymbals and accessories to stands with pipes from 15.9mm to 28.6mm in diameter.

Details:

- Quick-set tilter
- Quick-set cymbal mate

CYMBAL ATTACHMENT



CYA5E

Combines the MC5 compact clamp with the LCYE L-rod for mounting one cymbal to one boom arm. Can be clamped to rods from 9mm to 12mm in diameter or to the L-rod of a tom holder.

Details: Quick-set cymbal mate

TOM ATTACHMENT



MC69

Clamping this attachment on a 15.9mm to 28.6mm diameter pipe allows for direct set-up of toms. Even with a compact construction, the inclusion of the Omni-ball feature at the angle adjustment point lets you adjust toms to any angle.

TOM ADAPTER



MTH900AS

This adapter allows you to add single toms to stands using the flexibility and speed of TAMA's Omni-Ball/L-rod combination.

COWBELL ATTACHMENT



CBA5

Compact attachment for mounting hand percussion such as cowbells or tambourines. Combines the MC5 compact clamp and the LCB L-rod to provide set-up flexibility. The 3/8" L-rod fits most popular percussion instruments and accessories.

COWBELL ATTACHMENT



CBA56

Combines the universal clamp with the LCB L-rod to mount most popular percussion instruments and accessories. Can be attached to pipes ranging from 15.9mm to 28.6mm in diameter.

COWBELL ATTACHMENT



CBH20

This simple attachment allows cowbells to be mounted on the bass drum. The length and angle of the L-rod can be easily changed for optimum positioning.

COWBELL ATTACHMENT



CBH50

The position and angle of the cowbell are adjustable to your preference. The bass drum clamp is now equipped with rubber hoop protectors in order to prevent the hoop from becoming damaged.

HI-HAT ATTACHMENT



MHA823

This hi-hat attachment allows for better positioning of a hi-hat stand while using a double bass drum set-up. By connecting the MHA823 to the bass drum hoop, the hi-hat stand can be held upright without opening the hi-hat stand's legs. By utilizing TAMA Omni-Ball system, the clamp is now infinitely adjustable to any angle and enables even greater set-up flexibility. As well, rubber cushions are equipped to protect bass drum hoop from becoming damaged. The clamp is attachable to any hi-hat stand with a pipe diameter of 15.9 - 28.6mm by using the FastClamp Easy Set-Up System.

CYMBAL ATTACHMENT KIT



MCAX5366

A cymbal attachment kit is available for the Cocktail-JAM. These attachments have been simplified for portability. The hi-hat attachment allows you to open or close the hi-hats by simply flipping a lever.

- MCA53 cymbal attachment
- MXA56 closed hi-hat attachment

MICROPHONE STANDS

Just as many years ago, TAMA single-handedly altered the essence of the modern drum set through its re-invention of drum hardware—TAMA now turns that same degree of engineering dedication to yet another unevolved category of music gear: the microphone stand.

IRON WORKS STUDIO TELESCOPING BOOM STAND



MS737BK

- Vice-Grip Boom Tilter
- Sure-Cast Adjustment Collar
- Die-Cast Locking Thumb Nut
- Silent T-Handle
- Latch-Lok Sleeve Insert
- Height: 995mm - 1,665mm (39 3/16" - 65 1/2")
- Boom Arm: 1,055mm (41 1/2")
- Weight: 5.75kg
- Black Finish

IRON WORKS STUDIO TELESCOPING BOOM STAND



MS736BK

- Vice-Grip Boom Tilter
- Iron-Core Legs with Vibration-Isolating Rubber Feet
- Iron-Core Telescoping Boom Arm
- Silent T-Handle
- Detachable Boom Arm
- Height: 975-1650mm (38 3/8"-64 15/16")
- Boom arm : 505-850mm (19 7/8"-33 7/16")
- Weight : 5.4kg (11.9lbs)
- Black Finish

IRON WORKS STUDIO LOW PROFILE TELESCOPING BOOM STAND



MS736LBK

- Vice-Grip Boom Tilter
- Iron-Core Legs with Vibration-Isolating Rubber Feet
- Iron-Core Telescoping Boom Arm
- Silent T-Handle
- Detachable Boom Arm
- Height : 440mm - 605mm (17 5/16" - 23 13/16")
- Boom arm : 505mm - 850mm (19 7/8" - 33 7/16")
- Weight : 4.7kg (10.4lbs)
- Black Finish

IRON WORKS STUDIO ROUND BASE TELESCOPING BOOM STAND



MS736RBK

- Vice-Grip Boom Tilter
- Sure-Cast Adjustment Collar
- Die-Cast Locking Thumb Nut
- Round Cast Base
- Silent T-Handle
- Latch-Lok Sleeve Insert
- Iron-Core Telescoping Boom Arm
- Height: 990-1700mm (38 3/8"-64 15/16")
- Weight: 8.2kg
- Black Finish

IRON WORKS STUDIO ROUND BASE EXTRA LOW PROFILE TELESCOPING BOOM STAND



MS736RELBK

- Vice-Grip Boom Tilter
- Iron-Core Telescoping Boom Arm
- Silent T-Handle
- Detachable Boom Arm
- Heavy Round Cast Base
- Height : 280mm (11 1/32")
- Boom arm : 505mm - 850mm (19 7/8" - 33 7/16")
- Weight : 7.7kg (17.0lbs)
- Black Finish

IRON WORKS STUDIO SERIES EXTRA LOW TELESCOPING BOOM STAND



MS734ELBK

- Vice-Grip Boom Tilter
- Die-Cast Locking Thumb Nut
- Silent T-Handle
- Iron-Core Telescoping Boom Arm
- Height: 325mm (12 3/4")
- Boom arm: 335mm - 520mm (13 1/8" - 20 1/2")
- Weight: 4kg (8.8lbs)
- Black Finish

IRON WORKS TOUR TELESCOPING BOOM STAND



MS436BK

- Cast Grip Boom Tilter
- Die-Cast Locking Thumb Nut
- Sure-Cast Adjustment Collar
- Iron-Core Telescoping Boom Arm
- Detachable Boom Arm
- Height : 985mm - 1660mm (38 3/4" - 65 3/8")
- Boom arm : 845mm (33 1/4")
- Weight : 3.9kg (8.6lbs)
- Black Finish

IRON WORKS TOUR LOW PROFILE TELESCOPING BOOM STAND



MS436LBK

- Cast Grip Boom Tilter
- Die-Cast Locking Thumb Nut
- Sure-Cast Adjustment Collar
- Iron-Core Telescoping Boom Arm
- Detachable Boom Arm
- Height : 440mm - 605mm (17 5/16" - 23 13/16")
- Boom arm : 505mm - 845mm (19 7/8" - 33 1/4")
- Weight : 3.1kg (6.9lbs)
- Black Finish

IRON WORKS TOUR TABLE TOPSTAND



MS30BK

- Lighter Smaller Zinc Die-Cast Round Base
- 2 stage Aluminum Pipe Construction
- Height: 220mm - 370mm (8 5/8" - 14 9/16")
- Weight: 1.1kg
- Black Finish

BOOM STAND



MS205

- Cast Grip Boom Tilter
- Height : 960mm - 1600mm (37 13/16" - 63")
- Boom arm : 830mm (32 11/16")
- Weight : 3.2kg (7.1 lbs)
- Chrome Finish

BOOM STAND



MS205BK

- Cast Grip Boom Tilter
- Height : 960mm - 1600mm (37 13/16" - 63")
- Boom arm : 830mm (32 11/16")
- Weight : 3.2kg (7.1 lbs)
- Black Finish

BOOM STAND



MS205VBK

- Vice-Grip Boom Tilter
- Latch-Lok Sleeve Insert
- Height: 965mm - 1,600mm (38" - 63")
- Boom Arm : 830mm (32 11/16")
- Weight: 3.26kg (7.1lbs)
- Black Finish

LOW PROFILE BOOM STAND



MS205ST

- Cast Grip Boom Tilter
- Height : 430mm - 560mm (17 1/8" - 22 1/16")
- Boom arm : 510mm (20 1/16")
- Weight : 2.3kg (5.1 lbs)
- Chrome Finish

LOW PROFILE BOOM STAND



MS205STBK

- Cast Grip Boom Tilter
- Height : 430mm - 560mm (17 1/8" - 22 1/16")
- Boom arm : 510mm (20 1/16")
- Weight : 2.3kg (5.1 lbs)
- Black Finish

STRAIGHT STAND



MS200BK

- Height : 910 - 1550mm (36" - 61")
- Weight : 2.4kg (5.4lbs)
- Black Finish

STRAIGHT STAND WITH ROUND BASE



MS200DBK

- Cast Round Base with T-Bolt Pipe Fixing Device
- Height : 895 - 1510mm (35 1/4" - 59 7/16")
- Weight : 3.8kg (8.6lbs)
- Black Finish

DESK-MOUNTED MICROPHONE BOOM ARM



MSDA206BK

-Iron-Core Telescoping Boom Arm
-Cast Grip Boom Tilter
-Height memory lock
-Headset hanging hook
Height: 95 - 515mm (3 3/4" - 20 1/4")
Boom Arm: 450 - 800mm (17 3/4" - 31 1/2")
Weight : 1.6kg (3.6lbs)
Black Finish

MICROPHONE TELESCOPING BOOM ARM WITH CLAMP



MSCA734BK

-Iron-Core Telescoping Boom Arm
-Vice-Grip Boom Tilter
-Clamp holds pipes with diameters from 15-25.4mm (5/8"-1")
Boom Arm: 290-455mm (11 7/16"-17 15/16")
Weight : 0.87kg (1.9lbs)
Black Finish

BOOM ARM



MS736BB

Vice-Grip Boom Tilter with Iron-Core Telescoping Boom Arm

BOOM ARM



MS436BB

Cast-Grip Boom Tilter with Iron-Core Telescoping Boom Arm

TRI-LIFT ADAPTER



TLA3

An extremely innovative product, the TLA3 Tri-Lift Adaptor is highly useful for setting multiple microphone stands very close together. This adaptor lifts the mic stand's legs up and enables you to place another stand's legs underneath. (3pcs/Set)

CORD CLIP



CC5

For 15.9 mm (5/8") diameter tube. (3pcs/Set)

CORD CLIP



CC7

For 22.2 mm (7/8") diameter tube. (3pcs/Set)

DIE-CAST LOCKING THUMB NUT



DTLN3

For 3/8" connector
Not only does the thumb nut's larger, sure-grip design allow greater leverage for faster, easier set-up and breakdown, its high quality zinc threads and walls are built to handle pressure for years to come.

RUBBER FOOT



756-RF

TAMA's extra thick rubber foot covers "float" the stand, isolating the microphone from floor vibrations. (for 19.1mm diameter leg)

GUITAR STAND



839

-Adjustable Neck and Body Holder
-Glide-Tite Grip Joint
-Die-Cast Tripod Base

TAMA PERCUSSION

For more than 40 years, TAMA has been inspiring drummers around the world with its unique range of original percussion instruments. Combining the influences of global musical cultures with modern technology, TAMA has given drummers and percussionists of every genre a new lease on creativity with the unique voices these instruments provide.

GONG BASS DRUM



MAG20R

20"x14" Starclassic Maple Gong Bass Drum

MEG20R (Exotic Finishes)
MAG20R (Lacquer Finishes)
MRG20R (Duracover Finishes)

*Gong Bass Drums is available in all Starclassic Maple finishes (Exotic/ Lacquer / Duracover Wrap).
**Gong Bass Drums Shell Hardware is available in Chrome finish only.
***Hardware and tom arms not included.

METALWORKS "EFFECT" STEEL MINI-TYMP



MT68STBK

6"x4" + 8"x4"

Steel Mini-Tymp come with an L-rod (LLT) and multi-clamp (MC66).

METALWORKS "EFFECT" STEEL MINI-TYMP



MT810STBK

8"x4" + 10"x4"

Steel Mini-Tymp come with an L-rod (LLT) and multi-clamp (MC66).

JINGLE RING



TJR7

The Jingle Ring is a slim tambourine that can be mounted on a hi-hat stand or as a separate item. It features 9 pairs of nickel "jingles" that produce a bright, clear, tambourine sound.

OCTOBAN SET



7850N2H

2pc High-pitch set w/HOW29WN stand

OCTOBAN SET



7850N2L

2pc Low-pitch set w/HOW29WN stand

OCTOBAN SET



7850N4H

4pc High-pitch set w/HOW49WN stand

OCTOBAN SET



7850N4L

4pc Low-pitch set w/HOW49WN stand

OCTOBAN**OCT280N**
280mm (11") depth**OCTOBAN****OCT301N**
301mm (11 3/4") depth**OCTOBAN****OCT343N**
343mm (13 1/2") depth**OCTOBAN****OCT390N**
390mm (15 1/2") depth**OCTOBAN****OCT443N**
443mm (17 1/2") depth**OCTOBAN****OCT472N**
472mm (18 1/2") depth**OCTOBAN****OCT536N**
536mm (21") depth**OCTOBAN****OCT600N**
600mm (23 1/2") depth**OCTOBAN STAND****HOW29WN**
for 2pcs octobans**OCTOBAN STAND****HOW49WN**
for 4pcs octobans**OCTOBAN HOLDER FOR DRUM RACK****OA29**
for 2pcs octobans**OCTOBAN HOLDER FOR DRUM RACK****OA49**
for 4pcs octobans**PRACTICE TOOLS**

Our unique practice tools make your percussive education more enjoyable and productive.

PRACTICE PAD**TSP9**

This practice pad accurately imitates the natural feel & rebound of an acoustic snare drum. The wooden base and 6mm thick rubber playing surface offer excellent durability. This combination provides easy control and is ideal for hours long practice sessions. The non-slip base allows the practice pad to rest on a tabletop or snare drum without damaging the surface beneath.

- Unique Playing Surface
- A Natural Feel with the Perfect Bounce
- Portable Compact Size - 9"
- Non-Skid Soft Foam Base

PRACTICE PAD STAND**HS40TPN**

The HS40TPN practice pad stand can hold pads between 6 and 10 inches in diameter. The EP222 Extension Pipe sold separately.

- Single Braced Legs
- Height Adjustment Range w/o extension pipe: 580mm - 710mm (22 13/16" - 27 15/16")
- w/ extension pipe (EP222): 790mm - 1,065mm (31 1/8" - 41 15/16")

EXTENSION PIPE FOR PRACTICE PAD STAND**EP222**

The height of the HS40TPN can be easily extended by attaching the EP222 extension pipe between the upper and lower section of unit. No tools are required to install this product.

MESH HEAD**MH8T**

- MH8T (8")
- MH10T (10")
- MH12T (12")
- MH13T (13")
- MH14T (14")
- MH16T (16")
- MH18B (18")
- MH22B (22")

SOFT SOUND BEATER**BSQ10S**

Soft Sound Beater provides a significant decrease in volume, but allows you to use your regular bass drum pedal and bass drum head with a natural and accurate feel.

SOFT SOUND BEATER**BSQ5S**

Soft Sound Beater provides a significant decrease in volume, but allows you to use your regular bass drum pedal and bass drum head with a natural and accurate feel.

- Half size version for twin pedal users

SOFT SOUND RING



SSR8

The TAMA Soft Sound Ring is made of 6mm thick foam rubber. This drum accessory reduces the volume of an acoustic drum kit while retaining the natural tone of the shell.

SSR8 (8")
SSR10 (10")
SSR12 (12")
SSR13 (13")
SSR14 (14")
SSR16 (16")

SOFT SOUND PACKAGE

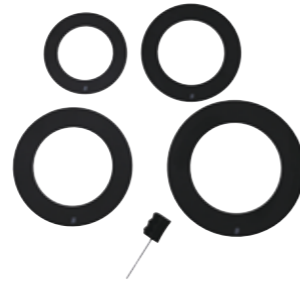

SSRP52K

22"BD 5pc kit configuration

The Soft Sound package reduces the volume of an acoustic drum kit while retaining the natural tone of the shell. It is designed to maintain the feel of playing an acoustic drum kit; a very important feature when playing in low volume situations.

-10", 12", 14", and 16" Soft Sound Ring
-Half Soft Sound Beater (BSQ5S)

SOFT SOUND PACKAGE

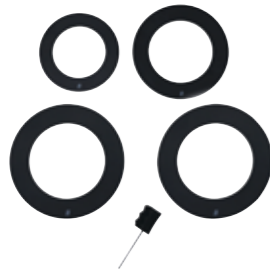

SSRP50

20"BD 5pc kit configuration

The Soft Sound package reduces the volume of an acoustic drum kit while retaining the natural tone of the shell. It is designed to maintain the feel of playing an acoustic drum kit; a very important feature when playing in low volume situations.

-10", 12", and 2pcs of 14" Soft Sound Ring
-Half Soft Sound Beater (BSQ5S)

SOFT SOUND PACKAGE

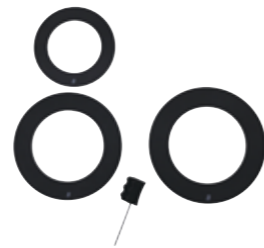

SSRP48

18"BD 4pc kit configuration

The Soft Sound package reduces the volume of an acoustic drum kit while retaining the natural tone of the shell. It is designed to maintain the feel of playing an acoustic drum kit; a very important feature when playing in low volume situations.

-10", 13", and 14" Soft Sound Ring
-Half Soft Sound Beater (BSQ5S)

CYMBAL MUTE



CM14HH

for 14" hi-hat cymbal

CYMBAL MUTE



CM1416

for 14" or 16" cymbal

CYMBAL MUTE



CM1820

for 18" or 20" cymbal

SILENT PRACTICE SET



SPP518CN

Mesh head for 18" bass drum
Mesh head for 10" tom tom
Mesh head for 12" tom tom
Mesh head for 14" floor tom & snare drum (x2)
Cymbal mute for 14" hi-hat cymbal
Cymbal mute for 14" or 16" cymbal
Cymbal mute for 18" or 20" cymbal

SILENT PRACTICE SET



SPP522C

Mesh head for 22" bass drum
Mesh head for 12" tom tom
Mesh head for 13" tom tom
Mesh head for 16" floor tom
Mesh head for 14" snare drum
Cymbal mute for 14" hi-hat cymbal
Cymbal mute for 14" or 16" cymbal
Cymbal mute for 18" or 20" cymbal

SILENT PRACTICE SET



SPP522KC

Mesh head for 22" bass drum
Mesh head for 10" tom tom
Mesh head for 12" tom tom
Mesh head for 16" floor tom
Mesh head for 14" snare drum
Cymbal mute for 14" hi-hat cymbal
Cymbal mute for 14" or 16" cymbal
Cymbal mute for 18" or 20" cymbal

SILENT TIPS



TCP20

TAMA TCP20 is a pair of silicone rubber tips that fit over most drum stick models. These tips make it easy and convenient to practice silently, anytime, anywhere.

ISO-BASE SOUND REDUCTION PAD SET



TIBS4

Designed for quiet practice at home, the Iso-Base Sound Reduction Pads offer superb floor vibration isolation. For use with cymbal stands, bass drum pedals, hi-hat stands, and even bass drum spurs, the Iso-Base pads are compact and lightweight for easy set-up, tear down, and portability.

- Including TIBP1 x 1 and TIBL1 x 3

ISO-BASE SOUND REDUCTION PEDAL PAD



TIBP1

The Pedal Pad offer bass drum pedal floor vibration isolation during home practice.

ISO-BASE SOUND REDUCTION LEG PAD



TIBL1

The Leg Pads offer floor vibration isolation during home practice for cymbal stands, hi-hat stands, and bass drum spurs.

TRAVELER PAD



TTP4BK

A compact and extremely portable 4" silicone practice pad that fits in your pocket. With a realistic feel and a low volume sound, you can practice anytime & anywhere.

-Textured Non-Slip Base
-Multi-Stack Design
-Portable Compact Size - 4"
-Color: Black

TRAVELER PAD



TTP4PK

A compact and extremely portable 4" silicone practice pad that fits in your pocket. With a realistic feel and a low volume sound, you can practice anytime & anywhere.

-Textured Non-Slip Base
-Multi-Stack Design
-Portable Compact Size - 4"
-Color: Pink

TRAVELER PAD



TTP4YL

A compact and extremely portable 4" silicone practice pad that fits in your pocket. With a realistic feel and a low volume sound, you can practice anytime & anywhere.

-Textured Non-Slip Base
-Multi-Stack Design
-Portable Compact Size - 4"
-Color: Yellow

BAGS

POWERPAD® BAG -Tom Tom-



PBT8

PBT8 (8"x7" Tom Tom)
PBT10 (10"x8" Tom Tom)
PBT12 (12"x9" Tom Tom)
PBT13 (13"x10" Tom Tom)

POWERPAD® BAG -Floor Tom-



PBF14

PBF14 (14"x14" Floor Tom)
PBF16 (16"x16" Floor Tom)

POWERPAD® BAG -Bass Drum-



PBB18

PBB18 (18"x16" Bass Drum or Floor Tom)
PBB20 (20"x18" Bass Drum)
PBB22 (22"x18" Bass Drum)
PBB24 (24"x18" Bass Drum)

POWERPAD® BAG -Snare Drum-



PBS1455

PBS1445 (14"x4.5" Snare Drum)
PBS1455 (14"x5.5" Snare Drum)
PBS1465 (14"x6.5" Snare Drum)
PBS1480 (14"x8" Snare Drum)

POWERPAD® BAG -Hardware-



PBH02L

880 (L) x 150 (W) x 200 (H) mm
(34 5/8" x 5 7/8" x 7 7/8")

-Suitable size for storing about 5 stand

POWERPAD® BAG -Hardware-



PBH05

850 (L) x 320 (W) x 220 (H) mm
(33 1/2" x 12 5/8" x 8 5/8")

-Suitable size for storing about 10 stands
-Equipped with durable wheels

POWERPAD® BAG -Cymbal-



PBC22

The POWERPAD® Series Cymbal Bag is a heavy duty bag designed to carry cymbals up to 22" in diameter. The main compartment contains (3) 22" dividers and the front side pocket contains (3) 15" dividers.

POWERPAD® BAG -Twin Pedal-



PBP200

The PBP200 can accommodate both single and double pedals.

450 (L) x 300 (W) x 200 (H) mm
(17 3/4" x 11 7/8" x 7 7/8")

POWERPAD® BAG -Single Pedal-



PBP100

The POWERPAD® Series bag for single pedal.

220 (D) x 190 (W) x 400 (H) mm
(8 5/8" x 7 1/2" x 15 3/4")

POWERPAD® BAG -Drum Throne-



PBTH15

-Carries any TAMA drum throne
-Carries 14" snare drum and snare drum stand
-Shoulder strap and handle for easy transportation

POWERPAD® BAG -Stick & Mallet-



PBS50

Stores about 24 pairs of sticks & mallets

-Large front pocket for sheet music
-Built-in hooks easily attach to floor tom
-Padded Shoulder strap
-Convenient inner pockets
-Height: 500mm
-Open Width: 580mm

POWERPAD® BAG -Stick-



PBS24

Stores about 12 pairs of sticks & mallets

POWERPAD® DESIGNER BAG -Drum Set-



TDSS52KBK

Black
22"x18" Bass Drum
10"x8" Tom Tom
12"x9" Tom Tom
16"x16" Floor Tom
14"x6.5" Snare Drum

-10mm thick inner cushions
-Ergonomic rubber handle
-A comfortable padded shoulder strap (for the snare drum bag)

POWERPAD® DESIGNER BAG -Drum Set-



TDSS52KBE

Beige
22"x18" Bass Drum
10"x8" Tom Tom
12"x9" Tom Tom
16"x16" Floor Tom
14"x6.5" Snare Drum

-10mm thick inner cushions
-Ergonomic rubber handle
-A comfortable padded shoulder strap (for the snare drum bag)

POWERPAD® DESIGNER BAG -Drum Set-



TDSS52KMG

Moss Green
22"x18" Bass Drum
10"x8" Tom Tom
12"x9" Tom Tom
16"x16" Floor Tom
14"x6.5" Snare Drum

-10mm thick inner cushions
-Ergonomic rubber handle
-A comfortable padded shoulder strap (for the snare drum bag)

POWERPAD® DESIGNER BAG -Drum Set-



TDSS52KNB

Navy Blue
22"x18" Bass Drum
10"x8" Tom Tom
12"x9" Tom Tom
16"x16" Floor Tom
14"x6.5" Snare Drum

-10mm thick inner cushions
-Ergonomic rubber handle
-A comfortable padded shoulder strap (for the snare drum bag)

POWERPAD® DESIGNER BAG -Drum Set-



TDSS52KWR

Wine Red
22"x18" Bass Drum
10"x8" Tom Tom
12"x9" Tom Tom
16"x16" Floor Tom
14"x6.5" Snare Drum

-10mm thick inner cushions
-Ergonomic rubber handle
-A comfortable padded shoulder strap (for the snare drum bag)

POWERPAD® DESIGNER BAG -8" Tom Tom-



TSBT8BK

Black
8"x7" Tom Tom

-10mm thick inner cushions
-Ergonomic rubber handle

POWERPAD® DESIGNER BAG -8" Tom Tom-



TSBT8BE

Beige
8"x7" Tom Tom
-10mm thick inner cushions
-Ergonomic rubber handle

POWERPAD® DESIGNER BAG -8" Tom Tom-



TSBT8MG

Moss Green
8"x7" Tom Tom
-10mm thick inner cushions
-Ergonomic rubber handle

POWERPAD® DESIGNER BAG -8" Tom Tom-



TSBT8NB

Navy Blue
8"x7" Tom Tom
-10mm thick inner cushions
-Ergonomic rubber handle

POWERPAD® DESIGNER BAG -8" Tom Tom-



TSBT8WR

Wine Red
8"x7" Tom Tom
-10mm thick inner cushions
-Ergonomic rubber handle

POWERPAD® DESIGNER BAG -14" Floor Tom-



TSBF14BK

Black
14"x14" Tom Tom
-10mm thick inner cushions
-Ergonomic rubber handle

POWERPAD® DESIGNER BAG -14" Floor Tom-



TSBF14BE

Beige
14"x14" Tom Tom
-10mm thick inner cushions
-Ergonomic rubber handle

POWERPAD® DESIGNER BAG -14" Floor Tom-



TSBF14MG

Moss Green
14"x14" Tom Tom
-10mm thick inner cushions
-Ergonomic rubber handle

POWERPAD® DESIGNER BAG -14" Floor Tom-



TSBF14NB

Navy Blue
14"x14" Tom Tom
-10mm thick inner cushions
-Ergonomic rubber handle

POWERPAD® DESIGNER BAG -14" Floor Tom-



TSBF14WR

Wine Red
14"x14" Tom Tom
-10mm thick inner cushions
-Ergonomic rubber handle

POWERPAD® DESIGNER BAG -Snare Drum-



TSDB1465BK

Black
14"x6.5" Snare Drum
-Convertible Backpack Straps
-20mm thick semi-hard cushion
-Backpack Straps and ergonomic rubber handle

POWERPAD® DESIGNER BAG -Snare Drum-



TSDB1465BE

Beige
14"x6.5" Snare Drum
-Convertible Backpack Straps
-20mm thick semi-hard cushion
-Backpack Straps and ergonomic rubber handle

POWERPAD® DESIGNER BAG -Snare Drum-



TSDB1465MG

Moss Green
14"x6.5" Snare Drum
-Convertible Backpack Straps
-20mm thick semi-hard cushion
-Backpack Straps and ergonomic rubber handle

POWERPAD® DESIGNER BAG -Snare Drum-



TSDB1465NB

Navy Blue
14"x6.5" Snare Drum
-Convertible Backpack Straps
-20mm thick semi-hard cushion
-Backpack Straps and ergonomic rubber handle

POWERPAD® DESIGNER BAG -Snare Drum-



TSDB1465WR

Wine Red
14"x6.5" Snare Drum
-Convertible Backpack Straps
-20mm thick semi-hard cushion
-Backpack Straps and ergonomic rubber handle

POWERPAD® DESIGNER BAG -Hardware-



THB02LBK

Black
880 (L) x 150 (W) x 200 (H) mm
(34 5/8" x 5 7/8" x 7 7/8")
-Suitable size for storing about 4 stands

POWERPAD® DESIGNER BAG -Hardware-



THB02LBE

Beige
880 (L) x 150 (W) x 200 (H) mm
(34 5/8" x 5 7/8" x 7 7/8")
-Suitable size for storing about 4 stands

POWERPAD® DESIGNER BAG -Hardware-



THB02LMG

Moss Green
880 (L) x 150 (W) x 200 (H) mm
(34 5/8" x 5 7/8" x 7 7/8")
-Suitable size for storing about 4 stands

POWERPAD® DESIGNER BAG -Hardware-



THB02LNB

Navy Blue
880 (L) x 150 (W) x 200 (H) mm
(34 5/8" x 5 7/8" x 7 7/8")
-Suitable size for storing about 4 stands

POWERPAD® DESIGNER BAG -Hardware-



THB02LWR

Wine Red
880 (L) x 150 (W) x 200 (H) mm
(34 5/8" x 5 7/8" x 7 7/8")
-Suitable size for storing about 4 stands

POWERPAD® DESIGNER BAG -Hardware-



THB04XLBK

Black
880 (L) x 180 (W) x 250 (H) mm
(34 5/8" x 7 1/16" x 9 13/16")
-Suitable size for storing HV5WN hardware kit
without drum pedal
(2-HC83BW, HS80W, HH605)

POWERPAD® DESIGNER BAG -Cymbal-



TCB22BK

Black
up to 22" Cymbal + 15" Cymbal (front side pocket)

-20mm thick semi-hard cushion
-Padded shoulder Straps and handle
-22" compartment dividers (3pcs) and 15" compartment dividers (3pcs) included

POWERPAD® DESIGNER BAG -Cymbal-



TCB22BE

Beige
up to 22" Cymbal + 15" Cymbal (front side pocket)

-20mm thick semi-hard cushion
-Padded shoulder Straps and handle
-22" compartment dividers (3pcs) and 15" compartment dividers (3pcs) included

POWERPAD® DESIGNER BAG -Cymbal-



TCB22MG

Moss Green
up to 22" Cymbal + 15" Cymbal (front side pocket)

-20mm thick semi-hard cushion
-Padded shoulder Straps and handle
-22" compartment dividers (3pcs) and 15" compartment dividers (3pcs) included

POWERPAD DESIGNER BAG -Cymbal-



TCB22NB

Navy Blue
up to 22" Cymbal + 15" Cymbal (front side pocket)

-20mm thick semi-hard cushion
-Padded shoulder Straps and handle
-22" compartment dividers (3pcs) and 15" compartment dividers (3pcs) included

POWERPAD® DESIGNER BAG -Cymbal-



TCB22WR

Wine Red
up to 22" Cymbal + 15" Cymbal (front side pocket)

-20mm thick semi-hard cushion
-Padded shoulder Straps and handle
-22" compartment dividers (3pcs) and 15" compartment dividers (3pcs) included

POWERPAD® DESIGNER BAG -Cajon-



TCB01BK

Black
330 (L) x 310 (W) x 520 (H) mm
(13" x 12 1/4" x 20 1/2")

-Backpack straps

POWERPAD® DESIGNER BAG -Cajon-



TCB01BE

Beige
330 (L) x 310 (W) x 520 (H) mm
(13" x 12 1/4" x 20 1/2")

-Backpack straps

POWERPAD® DESIGNER BAG -Cajon-



TCB01MG

Moss Green
330 (L) x 310 (W) x 520 (H) mm
(13" x 12 1/4" x 20 1/2")

-Backpack straps

POWERPAD® DESIGNER BAG -Cajon-



TCB01NB

Navy Blue
330 (L) x 310 (W) x 520 (H) mm
(13" x 12 1/4" x 20 1/2")

-Backpack straps

POWERPAD® DESIGNER BAG -Cajon-



TCB01WR

Wine Red
330 (L) x 310 (W) x 520 (H) mm
(13" x 12 1/4" x 20 1/2")

-Backpack straps

POWERPAD® DESIGNER BAG -Twin Pedal-



TPB200BK

Black
450 (L) x 200 (W) x 300 (H) mm
(17 3/4" x 7 7/8" x 11 3/4")

-Accommodate both single and double pedals
-Removable storage case for using as single pedal case

POWERPAD® DESIGNER BAG -Twin Pedal-



TPB200BE

Beige
450 (L) x 200 (W) x 300 (H) mm
(17 3/4" x 7 7/8" x 11 3/4")

-Accommodate both single and double pedals
-Removable storage case for using as single pedal case

POWERPAD® DESIGNER BAG -Twin Pedal-



TPB200MG

Moss Green
450 (L) x 200 (W) x 300 (H) mm
(17 3/4" x 7 7/8" x 11 3/4")

-Accommodate both single and double pedals
-Removable storage case for using as single pedal case

POWERPAD® DESIGNER BAG -Twin Pedal-



TPB200NB

Navy Blue
450 (L) x 200 (W) x 300 (H) mm
(17 3/4" x 7 7/8" x 11 3/4")

-Accommodate both single and double pedals
-Removable storage case for using as single pedal case

POWERPAD® DESIGNER BAG -Twin Pedal-



TPB200WR

Wine Red
450 (L) x 200 (W) x 300 (H) mm
(17 3/4" x 7 7/8" x 11 3/4")

-Accommodate both single and double pedals
-Removable storage case for using as single pedal case

POWERPAD® DESIGNER BAG -Stick-



TSB24BK

Black

-Main pockets for 12 pairs of sticks, and side pockets for accessories
-Built-in hooks easily attach to floor tom
-Shoulder strap for portability
-Convenient inner pockets
-Size: 460mm x 180mm
-Side Pocket: 260mm x 160mm

POWERPAD® DESIGNER BAG -Stick-



TSB24BE

Beige

-Main pockets for 12 pairs of sticks, and side pockets for accessories
-Built-in hooks easily attach to floor tom
-Shoulder strap for portability
-Convenient inner pockets
-Size: 460mm x 180mm
-Side Pocket: 260mm x 160mm

POWERPAD® DESIGNER BAG -Stick-



TSB24MG

Moss Green

-Main pockets for 12 pairs of sticks, and side pockets for accessories
-Built-in hooks easily attach to floor tom
-Shoulder strap for portability
-Convenient inner pockets
-Size: 460mm x 180mm
-Side Pocket: 260mm x 160mm

POWERPAD® DESIGNER BAG -Stick-



TSB24NB

Navy Blue

-Main pockets for 12 pairs of sticks, and side pockets for accessories
-Built-in hooks easily attach to floor tom
-Shoulder strap for portability
-Convenient inner pockets
-Size: 460mm x 180mm
-Side Pocket: 260mm x 160mm

POWERPAD® DESIGNER BAG -Stick-



TSB24WR

Wine Red

-Main pockets for 12 pairs of sticks, and side pockets for accessories
-Built-in hooks easily attach to floor tom
-Shoulder strap for portability
-Convenient inner pockets
-Size: 460mm x 180mm
-Side Pocket: 260mm x 160mm

POWERPAD® DESIGNER BAG -Stick-



TSB12BK

Black
Stores about 6 pairs of sticks

- Top of the bag open to take out stick easily
- Elastic band easily attach to floor tom
- Convenient inner pockets

POWERPAD® DESIGNER BAG -Stick-



TSB12BE

Beige
Stores about 6 pairs of sticks

- Top of the bag open to take out stick easily
- Elastic band easily attach to floor tom
- Convenient inner pockets

POWERPAD® DESIGNER BAG -Stick-



TSB12MG

Moss Green
Stores about 6 pairs of sticks

- Top of the bag open to take out stick easily
- Elastic band easily attach to floor tom
- Convenient inner pockets

POWERPAD® DESIGNER BAG -Stick-



TSB12NB

Navy Blue
Stores about 6 pairs of sticks

- Top of the bag open to take out stick easily
- Elastic band easily attach to floor tom
- Convenient inner pockets

POWERPAD® DESIGNER BAG -Stick-



TSB12WR

Wine Red
Stores about 6 pairs of sticks

- Top of the bag open to take out stick easily
- Elastic band easily attach to floor tom
- Convenient inner pockets

POWERPAD® DESIGNER BAG -Stick-



TSB12DBK

Black Denim
Stores about 6 pairs of sticks

- Top of the bag open to take out stick easily
- Elastic band easily attach to floor tom
- Convenient inner pockets

POWERPAD® DESIGNER BAG -Stick-



TSB12DBL

Blue Denim
Stores about 6 pairs of sticks

- Top of the bag open to take out stick easily
- Elastic band easily attach to floor tom
- Convenient inner pockets

VIVID COLLECTION STICK BAG



TVSB12BW

Introducing the fashion focused Vivid Collection Stick Bag. Featuring bold designs with vibrant colors, this bag will lift your spirits and inspire. Not only does it stand out visually, it's also highly functional, making it perfect for everyday practice and performances.

- Vivid colorful fabric (Blue x White)
- Shoulder strap makes the stick bag easy and comfortable to carry
- Hanging hook for quick & simple floor tom attachment
- Stores up to 6 pairs of sticks

VIVID COLLECTION STICK BAG



TVSB12YB

Introducing the fashion focused Vivid Collection Stick Bag. Featuring bold designs with vibrant colors, this bag will lift your spirits and inspire. Not only does it stand out visually, it's also highly functional, making it perfect for everyday practice and performances.

- Vivid colorful fabric (Yellow x Blue)
- Shoulder strap makes the stick bag easy and comfortable to carry
- Hanging hook for quick & simple floor tom attachment
- Stores up to 6 pairs of sticks

VIVID COLLECTION STICK BAG



TVSB12PV

Introducing the fashion focused Vivid Collection Stick Bag. Featuring bold designs with vibrant colors, this bag will lift your spirits and inspire. Not only does it stand out visually, it's also highly functional, making it perfect for everyday practice and performances.

- Vivid colorful fabric (Pink x Violet)
- Shoulder strap makes the stick bag easy and comfortable to carry
- Hanging hook for quick & simple floor tom attachment
- Stores up to 6 pairs of sticks

VIVID COLLECTION STICK BAG



TVSB120Y

Introducing the fashion focused Vivid Collection Stick Bag. Featuring bold designs with vibrant colors, this bag will lift your spirits and inspire. Not only does it stand out visually, it's also highly functional, making it perfect for everyday practice and performances.

- Vivid colorful fabric (Orange x Yellow)
- Shoulder strap makes the stick bag easy and comfortable to carry
- Hanging hook for quick & simple floor tom attachment
- Stores up to 6 pairs of sticks

STANDARD SERIES DRUM BAG SET



DSS52K

22"x18"BD
10"x8"TT
12"x9"TT
16"x16"FT
14"x6.5"SD

- 600 denier high density water resister surface
- Water resistant nylon with 10mm thick cushion
- Ergonomic rubber handles

STANDARD SERIES DRUM BAG SET



DSS50S

20"x18"BD
10"x8"TT
12"x9"TT
14"x14"FT
14"x6.5"SD

- 600 denier high density water resister surface
- Water resistant nylon with 10mm thick cushion
- Ergonomic rubber handles

STANDARD SERIES DRUM BAG SET



DSS62S

22"x18"BD
10"x8"TT
12"x9"TT
14"x14"FT
16"x16"FT
14"x6.5"SD

- 600 denier high density water resister surface
- Water resistant nylon with 10mm thick cushion
- Ergonomic rubber handles

STANDARD SERIES DRUM BAG SET



DSS48LJ

(for Club-JAM kit)
18"x12" BD
10"x8" TT
14"x7" FT & 13"x5" SD (1bag)

- 600 denier high density water resister surface
- Water resistant nylon with 10mm thick cushion
- Ergonomic rubber handles

STANDARD SERIES DRUM BAG SET



DSS28LJ

(for Club-JAM MINI kit)
18"x12" BD
12"x5" SD

- 600 denier high density water resister surface
- Water resistant nylon with 10mm thick cushion
- Ergonomic rubber handles

STANDARD SERIES DRUM BAG SET



DSS44LJ

(for Club-JAM Flyer kit)
14"x10" BD
10"x9" FT & 8"x6" TT (1 bag)
10"x5" SD bag

- 600 denier high density water resister surface
- Water resistant nylon with 10mm thick cushion
- Ergonomic rubber handles

STANDARD SERIES DRUM BAG SET



DSS48LJP

(for Club-JAM Pancake kit)
18"x4" BD
10"x3.5" TT
13"x3.5" FT
12"x4" SD

- 600 denier high density water resister surface
- Water resistant nylon with 10mm thick cushion
- Ergonomic rubber handles

STANDARD SERIES DRUM BAG SET



DSS48S

18"x14" BD
12"x9" TT
14"x14" FT
14"x6.5" SD

- 600 denier high density water resister surface
- Water resistant nylon with 10mm thick cushion
- Ergonomic rubber handles

STANDARD SERIES DRUM BAG SET



DSS72S

22"x18" BD
8"x7" TT
10"x8" TT
12"x9" TT
14"x14" FT
16"x16" FT
14"x6.5" SD

- 600 denier high density water resister surface
- Water resistant nylon with 10mm thick cushion
- Ergonomic rubber handles

STANDARD SERIES SNARE BAG



SBS14

14"x6.5" Snare Drum

- 600 denier high density water resister surface
- Water resistant nylon with 10mm thick cushion
- Ergonomic rubber handles
- Carrying strap with shoulder pads

STANDARD SERIES HARDWARE BAG



SBH01

(for Compact / Lightweight Hardware)
670 (L) x 180 (W) x 190 (H) mm

- 600 denier high density water resister surface
- Water resistant nylon with 10mm thick cushion
- Carrying strap with shoulder pads

STANDARD SERIES MICROPHONE STAND BAG



SBM01

Stores up to 6 pcs of Microphone Stands or 2pcs of Speaker Stands
1200 (L) x 220 (W) x 200 (H) mm

- 600 denier high density water resister surface
- Water resistant nylon with 10mm thick cushion
- Carrying strap with shoulder pad

ACCESSORIES

We offer many unique accessories to enhance your playing, set up, and tone of the drums.

RHYTHM WATCH HOLDER



RWH10

for RW200

TENSION WATCH



TW200

The TW200 TAMA Tension Watch is very compact and is equipped with an easy to read dial. It comes with a detachable nylon bumper to ensure consistent measuring distance from the hoop, resulting in an evenly tensioned drum for the best sound.

ACCESSORY TRAY



TAT10

- Tray size (inside dimension): 235mm x 254mm (9 1/4" x 10")
- Drink holder: up to diameter 90mm (3 1/2")
- Includes MC61 FastClamp for connecting stands with pipes from 15.9mm to 28.6mm in diameter.
- Includes 2- S-Hooks for hanging bags
- Rims can hold up to 16mm (0.63") diameter drum sticks
- Mounted 5/8" nut for straight mic stand on bottom of the tray
- Weight capacity: 2.5kg (5.5lbs)

DRUM STICK HOLDER



STH10

The STH10 Stick Holder is designed to hold spare sticks and can be attached to hardware anywhere on the drum kit.

- Size: 280mm(L) x 60mm(W) x 90mm(H)
(11 1/32" x 2 11/32" x 3 17/32")
- Storing 2 pairs of drumsticks
- The attachment for connecting stands with pipes from 15.9mm to 28.6mm in diameter.

GRIP WRAP



TGW10BK

(2prs / set)

TAMA's Grip Wrap is designed to provide the player with a comfortable, non-slip surface for their drumsticks.

- Non-Slip Surface
- Soft and Comfortable Feel
- Highly Durable Material Made in Japan

WOOD HOOP PROTECTOR



WHP2

(2pcs / set)

Special adhesive pieces protect your wood hoop from being scratched by preventing the bass drum pedal from twisting or slipping.

MULTI TOOL



TMT9

Quick access multi tool for drums
-Hex Wrench 5.0mm/4.0mm/3.0mm/2.5mm/
2.0mm, Keychain Link, Hex Nut Driver, Phillips
Screwdriver, Drum Keys (x2)

DRUM RUG -TAMA Logo Pattern-



TDR-TL

2,000mm x 1,800mm
(78 3/4" x 70 7/8")

- Non-slip design helps keep drums & hardware in place
- Extra-large size accommodates most drum setups
- Hook and loop fasteners for easy transport

RHYTHM WATCH



RW200

Tempo Range: 30-250 BPM
Tempo, Beat & Sound Memory: 30 Songs
Beats: 0-9
Display: LCD with BACK LIGHT
Size: 127 x 35 x 150mm (5" x 1.4" x 6")
Weight: 285g including battery
Power Supply: 9V Battery (S-006P) or DC9V
200mA adapter

RHYTHM WATCH MINI



RW30

Tempo Range: 30-250 BPM
Beats: 0-9
Display: LCD display with BACK LIGHT
Size: 61 x 25 x 118mm (2 1/2" x 1" x 4 5/8")
Weight: 90g including battery
Power Supply: 2 x AAA Batteries (3V)

DRUM RUG -TAMA Logo Pattern / Small-



TDRS-TL

1,680mm x 1,330mm
(66 1/8" x 52 3/8")

- Non-slip design helps keep drums & hardware in place
- Fits to accommodate compact drum set
- Hook and loop fasteners for easy transport

DRUM RUG -Oriental Pattern-

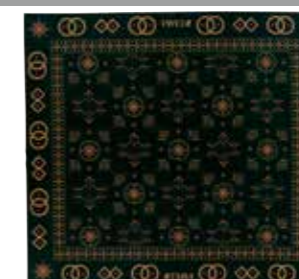

TDR-OR

2,000mm x 1,800mm
(78 3/4" x 70 7/8")

- Non-slip design helps keep drums & hardware in place
- Extra-large size accommodates most drum setups
- Hook and loop fasteners for easy transport

DRUM RUG -Southwestern Pattern-



TDR-SW

2,000mm x 1,800mm
(78 3/4" x 70 7/8")

- Non-slip design helps keep drums & hardware in place
- Extra-large size accommodates most drum setups
- Hook and loop fasteners for easy transport

DRUM RUG -Paisley Pattern-



TDR-PA

2,000mm x 1,800mm
(78 3/4" x 70 7/8")

- Non-slip design helps keep drums & hardware in place
- Extra-large size accommodates most drum setups
- Hook and loop fasteners for easy transport

REMO® FIBERSKYN POWERSTROKE 3 DIPLOMAT



RF22BMST

(TAMA Logo)
RF16BMST (16")
RF18BMST (18")
RF20BMST (20")
RF22BMST (22")
RF24BMST (24")
RF26BMST (26")

WHITE COATED HEADS



CT22BMOT

(TAMA & Starclassic Logo)
CT18BMOT (18")
CT20BMOT (20")
CT22BMOT (22")
CT24BMOT (24")
CT26BMOT (26")

FIBER LAMINATED HEADS



FB22BMFS

(TAMA & Starclassic Logo)
FB16BMFS (16")
FB18BMFS (18")
FB20BMFS (20")
FB22BMFS (22")
FB24BMFS (24")

BLACK HEADS



BK22BMTT

(TAMA & Starclassic Logo)
BK16BMTT (16")
BK18BMTT (18")
BK20BMTT (20")
BK22BMTT (22")
BK24BMTT (24")
BK26BMTT (26")

SMOOTH WHITE HEADS



SW22BMTT

(TAMA & Starclassic Logo)
SW16BMTT (16")
SW18BMTT (18")
SW20BMTT (20")
SW22BMTT (22")
SW24BMTT (24")

FIBER LAMINATED HEADS -BLACK-



BK22BMFH

(TAMA Logo)
BK20BMFH (20")
BK22BMFH (22")
BK24BMFH (24")

WHITE COATED HEADS -TAMA LOGO-



CT22BMSV

(TAMA Logo)
CT18BMSV (18")
CT20BMSV (20")
CT22BMSV (22")
CT24BMSV (24")

BLACK HEADS -TAMA LOGO-



BK22BMWS

(TAMA Logo)
BK20BMWS (20")
BK22BMWS (22")
BK24BMWS (24")

DRUM KEY



TDR10

Chrome

DRUM KEY



TDR10BN

Black Nickel

DRUM KEY



TDR05

TENSION LOCK



TTL10

(10pcs/set)

The Tension Lock prevents tension bolts from loosening while playing by simply set it on the tension bolt head. You can tune the drum without having to detach the Tension Lock, thanks to an elastic O-ring around its hole.

RING MUTE



RM14P3

(3pcs/set)
A 1" wide thin plastic 14" diameter snare drum mute. Place it on the batter side head to cut out overtones and achieve a tighter & dryer sound.

DIE-CAST HOOPS



MDH14-10

TAMA's die-cast hoops deliver an incredibly sharp, solid rim shot that cannot be found in any other hoop.

MDH14-8 (14" 8 hole batter side)
MDH14S-8 (14" 8 hole snare side)
MDH14-10 (14" 10 hole batter side)
MDH14S-10 (14" 10 hole snare side)

2.3mm BRASS MIGHTY HOOPS



MFB14-10N

Brass Mighty Hoop provides a warm and open sound with mild attack and long sustain.

MFB14-10N (14" 10 hole batter side)
MFB14S-10N (14" 10 hole snare side)

2.3mm STEEL MIGHTY HOOPS



MFM14-10

Steel Mighty Hoop provides a bright and open sound.

MFM14-8 (14" 8 hole batter side)
MFM14S-8 (14" 8 hole snare side)
MFM14-10 (14" 10 hole batter side)
MFM14S-10 (14" 10 hole snare side)

2.3mm SOUND ARC HOOPS



MSH1410

Steel Sound Arc Hoop enhances the natural tone of the snare drum and offers sensitivity, precise tuning, and control.

MSH148 (14" 8 hole batter side)
MSH1410 (14" 10 hole batter side)
MSH14S8 (14" 8 hole snare side)
MSH14S10 (14" 10 hole snare side)

2.3mm BRASS SOUND ARC HOOPS



MSB148D

Brass Sound Arc Hoop provides an open sound with rich harmonic overtones, made of brass with an inward curved shape.

MSB148D (14" 8 hole batter side)
MSB14S8D (14" 8 hole snare side)

CUSTOMIZED BRASS MIGHTY HOOPS



MSP14-8

Customized Brass Mighty Hoop provides a sharper and brighter attack with rich harmonic overtones, made of brass with a slightly shaved down edge.

MSP14-8 (14" 8 hole batter side)
MSP14S-8 (14" 8 hole snare side)

MAPLE WOOD HOOPS



WMH1408B

Wood Hoop provides a warm, woody sound with soft attack. Can be mounted on a standard 14" snare drum stand.

WMH1408B (14" 8 hole batter side)
WMH1408S (14" 8 hole snare side)

SUPER SENSITIVE HI-CARBON SNARE WIRES



MS20RL14C

Super Sensitive Hi-Carbon Snare Wire fits more closely to the snare side head, providing greater sensitivity and brighter, crisper sound.

MS20RL13C (13" 20-strand Hi-Carbon Steel)
MS20RL14C (14" 20-strand Hi-Carbon Steel)

SUPER SENSITIVE HI-CARBON SNARE WIRE FOR CONCERT



MS20L14C8

A thin brass plate and softer hi-carbon coils respond to even the softest touch on the edge of the batter head.

MS20L14C8 (14" 20-strand Hi-Carbon Steel)

STAINLESS STEEL STRAIGHT SNARE WIRE



MS20M14ST

20 strands steel straight wire for concert. Extra short sustain, dark and crisp.

MS20M14ST (14" 20-strand Steel)

STARCLASSIC SNARE WIRES -CARBON STEEL-



MS20SN14S

MS20SN10S (10" 20-strand Carbon Steel)
MS20SN12S (12" 20-strand Carbon Steel)
MS20SN13S (13" 20-strand Carbon Steel)
MS20SN14S (14" 20-strand Carbon Steel)

STARCLASSIC SNARE WIRES -BELL BRASS-



MS20SN14B

The MS20SN14B features bell brass strands for greater sensitivity.

MS20SN14B (14" 20-strand Bell Brass)

STARCLASSIC SNARE WIRES -HI-CARBON STEEL-



MS20SN14C

MS20SN13C (13" 20-strand Hi-Carbon Steel)
MS20SN14C (14" 20-strand Hi-Carbon Steel)

REGULAR SNARE WIRES -CARBON STEEL-



MS12R14S

(14" 12-strand Carbon Steel)

REGULAR SNARE WIRES -CARBON STEEL-



MS20R14S

(14" 20-strand Carbon Steel)

REGULAR SNARE WIRES -CARBON STEEL-



MS30R14S

(14" 30-strand Carbon Steel)

REGULAR SNARE WIRES -CARBON STEEL-



MS42R14S

(14" 42-strand Carbon Steel)

REGULAR SNARE WIRES -HI-CARBON STEEL-



MS42R14C

(14" 42-strand Hi-Carbon Steel)

HOLD TIGHT™ WASHERS



SRW620P

(20pcs/set)
The rubber rings inside of the cup-shaped stainless steel washers absorb impact vibrations and keep the hoop and tension bolts in constant contact to prevent from loosening of tension.

PLASTIC WASHERS



PW620

(20pcs/set)
2.5mm thick nylon washers decrease noise and make tuning easier and more stable.

METAL WASHERS



MW620

(20pcs/set)
Standard metal tension bolt washers.

SNARE WIRE STRAPS



MST20

(2pcs/set)
These flexible yet durable 15mm wide nylon snare wire straps are featured on most of TAMA snare drums.

SNARE WIRE STRINGS



SPC50P4

(2prs/pack)
The amazingly durable and flexible snare wire string is made of Dupont Kevlar® cable wrapped in polyester fiber for an even higher tensile strength than steel wire. (Kevlar® is a registered trademark of Dupont® Corporation.)

DYNA BEATER



BDY30FB

Featuring black felt and a slightly tapered shape, this traditional style beater provides impact to the bass drum head surface evenly to maximize clear, dynamic articulation.

POWER-STRIKE COBRA BEATER



CB900PS

Felt

ACCU-STRIKE COBRA BEATER



CB900AS
Rubber

COBRA BEATER -Felt-



CB90F
Felt

DUAL SIDED BEATER -Felt-



DS30G
Felt

DUAL SIDED BEATER -Rubber-



DS30R
Rubber

COBRA BEATER -Rubber-



CB90R
Rubber

COBRA BEATER -Wood-



CB90W
Wood

THE CLASSIC BEATER -Felt-



CLB30F
Felt

TRADITIONAL BEATER -Felt-



TTB30F
Felt

POWER-STRIKE COBRA BEATER HEAD



CB900PSH
Felt

ACCU-STRIKE COBRA BEATER HEAD



CB900ASH
Rubber

TRADITIONAL BEATER -Wood-



TTB30W
Wood

TOE STOPPER



HP900-81

COBRA BEATER HEAD -Felt-



CB90FH
Felt

COBRA BEATER HEAD -Rubber-



CB90RH
Rubber

BEATER BALANCER



BC7

TIGHT LOCK



TLK5

COBRA BEATER HEAD -Wood-



CB90WH
Wood

DUAL SIDED BEATER -Felt-



DS30
Felt

SPRING FOR SPEED COBRA



HP910-7S

SPRING -Regular-



HP900-7R

SPRING -Heavy-**HP900-7H****COBRA COIL****CC900S**

The Cobra Coil is a steel spring which assists in the return of the footboard to its original position. It be adjusted to different positions, forward or backward, on the base plate.

DRUM HAMMER**DH7****TWIN PEDAL ATTACHMENT****TPA90**

Specially designed attachment to connect Speed Cobra and Iron Cobra 900 series pedals with Speed Cobra and Iron Cobra 900 series Hi-hat stands.

DYNA-SYNC PEDAL CASE -SINGLE-**PCDS1**

PCDS1 (for Dyna-Sync Single Pedal)

**DYNA-SYNC PEDAL CASE -TWIN-****PCDS1TW**

PCDS1TW (for Dyna-Sync Twin Pedal)

**IRON COBRA PEDAL CASE -SINGLE-****PC900S**

PC900S (for Iron Cobra Single Pedal)

**IRON COBRA PEDAL CASE -TWIN-****PC900TW**

PC900TW (for Iron Cobra Twin Pedal)

**SPEED COBRA PEDAL CASE -SINGLE-****PC910S**

PC910S (for Speed Cobra Single Pedal)

**SPEED COBRA PEDAL CASE -TWIN-****PC910TW**

PC910TW (for Speed Cobra Twin Pedal)

**1ST CHAIR ROUND RIDER XL SEAT -Cloth Top-****HTS8BC**

You can improve your existing throne with the firm support and comfort of 1st Chair seats.

**1ST CHAIR ROUND RIDER XL SEAT****HTS8B**

You can improve your existing throne with the firm support and comfort of 1st Chair seats.

**1ST CHAIR ROUND RIDER XL SEAT -Red-****HTS8R**

You can improve your existing throne with the firm support and comfort of 1st Chair seats.

**1ST CHAIR ERGO-RIDER SEAT -Cloth Top-****HTS7BC**

You can improve your existing throne with the firm support and comfort of 1st Chair seats.

**1ST CHAIR ERGO-RIDER SEAT****HTS7B**

You can improve your existing throne with the firm support and comfort of 1st Chair seats.

**1ST CHAIR GLIDE RIDER SEAT -Cloth Top-****HTS5BCN**

You can improve your existing throne with the firm support and comfort of 1st Chair seats.

**1ST CHAIR WIDE RIDER SEAT -Cloth Top-****HTS5BC**

You can improve your existing throne with the firm support and comfort of 1st Chair seats.

**1ST CHAIR WIDE RIDER SEAT****HTS5B**

You can improve your existing throne with the firm support and comfort of 1st Chair seats.

**1ST CHAIR ROUND RIDER SEAT -Cloth Top-****HTS4BC**

You can improve your existing throne with the firm support and comfort of 1st Chair seats.

**1ST CHAIR ROUND RIDER SEAT****HTS4B**

You can improve your existing throne with the firm support and comfort of 1st Chair seats.



1ST CHAIR THRONE BASE -HYDRAULIX-



HSB5N

*Seat holder included.

You can improve your existing throne or seat by changing the legs to one of the 1st Chair individual throne bases. The Hydraulix throne base comes with a seat holder with an adjustment lever.

1ST CHAIR THRONE BASE -Quartet-



HSB4N

You can improve your existing throne or seat by changing the legs to one of the 1st Chair individual throne bases. (diameter of upper rods: 22.2mm).

1ST CHAIR THRONE BASE -Trio-



HSB3N

You can improve your existing throne or seat by changing the legs to one of the 1st Chair individual throne bases. (diameter of upper rods: 22.2mm).

1ST CHAIR THRONE BASE -Trio-



HSB3

for Round Rider Series

You can improve your existing throne or seat by changing the legs to one of the 1st Chair individual throne bases. (diameter of upper rods: 22.2mm).

1ST CHAIR BACKREST ATTACHMENT



HTB5B

for any 1st Chair thrones

Sitting on a throne for a long period of time is tough on your back. The HTB5B can be adjusted up and down AND forward AND it can be detached from the seat when the gig is done. Slick!

TAMA LOGO STICKER -White-



TLS100WH

TLS120WH 60mm x 280mm
TLS100WH 50mm x 230mm
TLS80WH 40mm x 190mm
TLS70WH 35mm x 150mm

TAMA LOGO STICKER -Black-



TLS100BK

TLS120BK 60mm x 280mm
TLS100BK 50mm x 230mm
TLS80BK 40mm x 190mm
TLS70BK 35mm x 150mm

MEMORY LOCK



ML11

for 10.5mm diameter L-rod

MEMORY LOCK



ML12

for 10.5-12mm diameter boom arm

MEMORY LOCK



ML191C

for 19.1mm diameter pipe

MEMORY LOCK



ML191N

for 19.1mm diameter pipe

MEMORY LOCK



ML222C

for 22.2mm diameter pipe

MEMORY LOCK



ML222NT

for 22.2mm diameter pipe

MEMORY LOCK



ML254TC

for 25.4mm diameter pipe

MEMORY LOCK



ML254C

for 25.4mm diameter pipe

MEMORY LOCK



ML28C

for 28.6mm diameter pipe

QUICK-SET CYMBAL MATE



QC8

(M8)

QUICK-SET CYMBAL MATE (4pcs/set)



QC8-B4

(M8: 4pcs/pack)

CYMBAL MATE



CM8P

(M8: 2pcs/pack)

RING-TRUE FELT for STAR HARDWARE



RTF35P

(2pcs/pack)

FELT WASHER



7081P
(2pcs/pack)

REVERSIBLE CYMBAL BOTTOM



RB8P
(M8: 2pcs/pack)

STAR HARDWARE CYMBAL BOTTOM



CB8P
(M8: 2pcs/pack)

STAR HARDWARE CYMBAL PROTECTION SLEEVE



CPS8P
(M8: 2pcs/pack)

HAT STACK



CSH5
- Easily attach a small cymbal to hi-hat rod measuring up to 7mm in diameter
- Compact size and lightweight for easy transport and storage - 25mm (1") diameter x 40mm (1.5") height
- Ability to adjust cymbal sustain

SIZZLE TOUCH DROP CLUTCH



STDC7
TAMA's Sizzle Touch Drop Clutch allows you to adjust the gap between the top and bottom cymbals, allowing for fine adjustments to achieve the desired open sound.

QUICK-SET HI-HAT CLUTCH



QHC7
With just one touch, the Quick-Set Clutch can be attached or removed - simply push the button on the side of the clutch.
(Fits 7mm or smaller diameter pull rod)

SWING LOCK CLUTCH



SLC08
This allows the top hi-hat cymbal to float more freely, maximizing the natural resonance of the cymbals.
(Fits 6.3mm diameter pull rod)

SECURITY CLUTCH



CL08
Having your hi-hat clutch come loose is now a thing of the past with TAMA's Security Clutch. When the T-bolt is tightened, bottom lock nut and top section press on the rod for complete security.
(Fits 6.3mm diameter pull rod)

HI-HAT TENSION RODS



HH905-3/HH905D3S
Tension Rod w/ Plastic Nut (M6)
HH905-3 (Long / 500mm (19 11/16"))
HH905D3S (Short / 350mm (13 3/4"))

REMOTE HI-HAT STAND CABLE

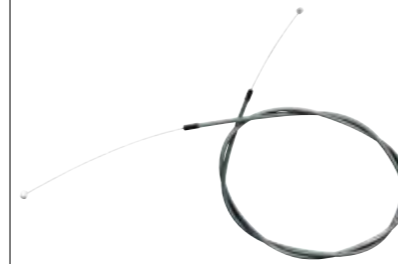

HH905RH2L/HH905RH2S
Exchangeable Cable for HH905RH
HH905RH2L (Long / 2,300mm (90 1/2"))
HH905RH2S (Short / 1,200mm (47 1/4"))

HI-HAT CLUTCH FELT WASHERS



CL08-13P
(2pcs/pack)

QUICK-LOCK TOM BRACKET



MQMP-TCH
(for tom tom/Chrome)
-Quick and easy setup in position
-Enhanced resonance with rubber lining

QUICK-LOCK TOM BRACKET



MQMP-TBN
(for tom tom/Black Nickel)
-Quick and easy setup in position
-Enhanced resonance with rubber lining

QUICK-LOCK TOM BRACKET



MQMP-FCH
(for floor tom/Chrome)
-Quick and easy setup in position
-Enhanced resonance with rubber lining

QUICK-LOCK TOM BRACKET



MQMP-FBN
(for floor tom/Black Nickel)
-Quick and easy setup in position
-Enhanced resonance with rubber lining

SOUND FOCUS PAD -for Cocktail-JAM-



SFP530
Bass Drum Mute for Cocktail-JAM kits

TAMA LOGO T-SHIRT BLACK



TAMT004
Available size: S/M/L/XL/XXL
TAMT004S
TAMT004M
TAMT004L
TAMT004XL
TAMT004XXL

TAMA "T" LOGO T-SHIRT BLACK



TAMT006
Available size: S/M/XXL
TAMT006S
TAMT006M
TAMT006XXL

TAMA BLACKLOGO T-SHIRT BLACK



TAMT007
Available size: L/XL/XXL
TAMT007L
TAMT007XL
TAMT007XXL

TAMA LOGO PULLOVER HOODIE



TAMP001

Available size: S/M/XXL

TAMP001S
TAMP001M
TAMP001XXL

TAMA WATER BOTTLE



TAMB001

Capacity: 500ml / 16.9oz
-Materials: Tritan (Bottle) / Polypropylene (Lid)
- Upper temperature tolerance: 100°C / 212°F
- Lower temperature tolerance: -10°C / 14°F
- BPA Free

TAMA LOGO LANYARD



TNKS001

-Length: 500 mm
-Width: 15 mm
-Safety breakaway release
-Material: Polyester

TAMA LOGO PIN



TMPIN001

-Length: 10.5 mm
-Width: 38 mm
-Height: 10mm
-Material: Nickel Plated Brass

DRUM STICKS

TAMA drum sticks are molded under strict quality control standards from carefully selected wood materials and are renowned for their consistent high quality.

ORIGINAL SERIES STICK -Japanese Oak-

0213-B

Diameter: 13mm (0.510")
Length: 406mm (16")
Tip Style: Ball

MADE IN JAPAN



ORIGINAL SERIES STICK -Japanese Oak-

0214-B

Diameter: 14mm (0.550")
Length: 406mm (16")
Tip Style: Ball

MADE IN JAPAN



ORIGINAL SERIES STICK -Japanese Oak-

0215-B

Diameter: 15mm (0.590")
Length: 406mm (16")
Tip Style: Ball

MADE IN JAPAN



ORIGINAL SERIES STICK -Japanese Oak-

0216-B

Diameter: 16mm (0.630")
Length: 406mm (16")
Tip Style: Ball

MADE IN JAPAN



ORIGINAL SERIES STICK -Japanese Oak-

0213-P

Diameter: 13mm (0.510")
Length: 406mm (16")
Tip Style: Popular

MADE IN JAPAN



ORIGINAL SERIES STICK -Japanese Oak-

0214-P

Diameter: 14mm (0.550")
Length: 406mm (16")
Tip Style: Popular

MADE IN JAPAN



ORIGINAL SERIES STICK -Japanese Oak-

0215-P

Diameter: 15mm (0.590")
Length: 406mm (16")
Tip Style: Popular

MADE IN JAPAN



ORIGINAL SERIES STICK -Japanese Oak-

0214-S

Diameter: 14mm (0.550")
Length: 406mm (16")
Tip Style: Small

MADE IN JAPAN



ORIGINAL SERIES STICK -Japanese Oak-

0215-S

Diameter: 15mm (0.590")
Length: 406mm (16")
Tip Style: Small



TRADITIONAL SERIES STICK -Japanese Oak-

7A

Diameter: 13mm (0.510")
Length: 390mm (15 3/8")
Tip Style: 7A



TRADITIONAL SERIES STICK -Japanese Oak-

7AN

Diameter: 13mm (0.510")
Length: 390mm (15 3/8")
Tip Style: 7A (Nylon)



TRADITIONAL SERIES STICK -Japanese Oak-

5A

Diameter: 14mm (0.550")
Length: 406mm (16")
Tip Style: 5A



TRADITIONAL SERIES STICK -Japanese Oak-

5AN

Diameter: 14mm (0.550")
Length: 406mm (16")
Tip Style: 5A (Nylon)



TRADITIONAL SERIES STICK -Japanese Oak-

8A

Diameter: 14mm (0.550")
Length: 406mm (16")
Tip Style: 8A



TRADITIONAL SERIES STICK -Japanese Oak-

5B

Diameter: 15mm (0.590")
Length: 406mm (16")
Tip Style: 5B



TRADITIONAL SERIES STICK -Japanese Oak-

5BN

Diameter: 15mm (0.590")
Length: 406mm (16")
Tip Style: 5B (Nylon)



TRADITIONAL SERIES STICK -American Hickory-

H7A

Diameter: 13mm (0.510")
Length: 390mm (15 3/8")
Tip Style: 7A



TRADITIONAL SERIES STICK -American Hickory-

H5A

Diameter: 14mm (0.550")
Length: 406mm (16")
Tip Style: 5A



TRADITIONAL SERIES STICK -American Hickory-

H8A

Diameter: 14mm (0.550")
Length: 406mm (16")
Tip Style: 8A



TRADITIONAL SERIES STICK -American Hickory-

H5B

Diameter: 15mm (0.590")
Length: 406mm (16")
Tip Style: 5B



TRADITIONAL SERIES STICK -Maple-

M-JAZZ

Diameter: 13mm (0.510")
Length: 406mm (16")
Tip Style: JAZZ



TRADITIONAL SERIES STICK -Maple-

M-JAZZ-2

Diameter: 14mm (0.550")
Length: 393mm (15 15/32")
Tip Style: Acorn



TRADITIONAL SERIES STICK -Maple-

M-JAZZ-3

Diameter: 12.75mm (0.500")
Length: 397mm (15 5/8")
Tip Style: Oval



TRADITIONAL SERIES STICK -Maple-

M-JAZZ-N

Diameter: 13mm (0.510")
Length: 406mm (16")
Tip Style: Nylon



OAK LAB SERIES -Smash-

OL-SM

Weight and balance for huge power.

Diameter: 15mm (0.590")
Length: 419mm (16 1/2")
Tip Style: Acorn



OAK LAB SERIES -Resonator-

OL-RE

Heavy for rich tones. Quick rebound.

Diameter: 15.25mm (0.600")
Length: 410mm (16 5/32")
Tip Style: Arrow



OAK LAB SERIES -Fast Blast-

OL-FA

(Natural / Uncoated)
Modified 5A for more speed. Large tip and Oak enhances volume.

Diameter: 14mm (0.550")
Length: 406mm (16")
Tip Style: Large Ball



OAK LAB SERIES -Swingin'-

OL-SW

Oak provides a bright cymbal tone and enhanced cross stick sound.

Diameter: 12.75mm (0.500")
Length: 403mm (15 7/8")
Tip Style: Oval



OAK LAB SERIES -Full Balance-

OL-FU

MADE IN JAPAN

Weighted for accuracy and control.

Diameter: 14.5mm (0.570")
Length: 406mm (16")
Tip Style: True Round



REDZONE -Japanese Oak-

5ARZ

MADE IN JAPAN

(Silver Logo)

Diameter: 14mm (0.550")
Length: 419mm (16 1/2")
Tip Style: 5A (Nylon)



REDZONE -Japanese Oak-

5BRZ

MADE IN JAPAN

(Silver Logo)

Diameter: 15mm (0.590")
Length: 419mm (16 1/2")
Tip Style: 5B (Nylon)



RHYTHMIC FIRE -Japanese Oak-

7A-F

MADE IN JAPAN

(Natural)

Diameter: 13mm (0.510")
Length: 390mm (15 3/8")
Tip Style: 7A



RHYTHMIC FIRE -Japanese Oak-

5A-F

MADE IN JAPAN

(Natural)

Diameter: 14mm (0.550")
Length: 406mm (16")
Tip Style: 5A



RHYTHMIC FIRE -Japanese Oak-

5B-F

MADE IN JAPAN

(Natural)

Diameter: 15mm (0.590")
Length: 406mm (16")
Tip Style: 5B



RHYTHMIC FIRE -Japanese Oak-

7A-F-BS

MADE IN JAPAN

(Black, Silver Pattern)

Diameter: 13mm (0.510")
Length: 390mm (15 3/8")
Tip Style: 7A



RHYTHMIC FIRE -Japanese Oak-

5A-F-BS

MADE IN JAPAN

(Black, Silver Pattern)

Diameter: 14mm (0.550")
Length: 406mm (16")
Tip Style: 5A



RHYTHMIC FIRE -Japanese Oak-

5B-F-BS

MADE IN JAPAN

(Black, Silver Pattern)

Diameter: 15mm (0.590")
Length: 406mm (16")
Tip Style: 5B



RHYTHMIC FIRE -Japanese Oak-

7A-F-BR

MADE IN JAPAN

(Black, Red Pattern)

Diameter: 13mm (0.510")
Length: 390mm (15 3/8")
Tip Style: 7A



RHYTHMIC FIRE -Japanese Oak-

5A-F-BR

MADE IN JAPAN

(Black, Red Pattern)

Diameter: 14mm (0.550")
Length: 406mm (16")
Tip Style: 5A



RHYTHMIC FIRE -Japanese Oak-

5B-F-BR

MADE IN JAPAN

(Black, Red Pattern)

Diameter: 15mm (0.590")
Length: 406mm (16")
Tip Style: 5B



STICKS OF DOOM -Japanese Oak-

7A-S

MADE IN JAPAN

(Natural)

Diameter: 13mm (0.510")
Length: 390mm (15 3/8")
Tip Style: 7A



STICKS OF DOOM -Japanese Oak-

5A-S

MADE IN JAPAN

(Natural)

Diameter: 14mm (0.550")
Length: 406mm (16")
Tip Style: 5A



STICKS OF DOOM -Japanese Oak-

5B-S

MADE IN JAPAN

(Natural)

Diameter: 15mm (0.590")
Length: 406mm (16")
Tip Style: 5B



STICKS OF DOOM -Japanese Oak-

7A-S-BS

MADE IN JAPAN

(Black, Silver Pattern)

Diameter: 13mm (0.510")
Length: 390mm (15 3/8")
Tip Style: 7A



STICKS OF DOOM -Japanese Oak-

5A-S-BS

MADE IN JAPAN

(Black, Silver Pattern)

Diameter: 14mm (0.550")
Length: 406mm (16")
Tip Style: 5A



STICKS OF DOOM -Japanese Oak-

5B-S-BS

MADE IN JAPAN

(Black, Silver Pattern)

Diameter: 15mm (0.590")
Length: 406mm (16")
Tip Style: 5B



SUEDE-GRIP DRUM STICKS -Japanese Oak-

5A-SG

MADE IN JAPAN

(SUEDE-GRIP Finish)

Diameter: 14mm (0.550")
Length: 406mm (16")
Tip Style: 5A



SUEDE-GRIP DRUM STICKS -Japanese Oak-

5B-SG

MADE IN JAPAN

(SUEDE-GRIP Finish)

Diameter: 15mm (0.590")
Length: 406mm (16")
Tip Style: 5B



DIRK VERBEUREN MODEL -Japanese Oak-

O-DVM2

Dirk Verbeuren (MEGADETH)

Diameter: 16mm (0.630")
Length: 406mm (16")



ALEX RÜDINGER MODEL -American Hickory-

H-RUDI

Alex Rüdinger

Diameter: 16mm (0.630")
Length: 416mm (16 3/8")
Non-Slipping Lacquer Finish



MARCHING PERCUSSION

After a long period of planning and experimentation, TAMA Marching Percussion is finally complete. High durability, various unique features for function and comfort, and revolutionary improvements allow total customized playability for everyone.

FIELDSTAR MARCHING SNARE DRUMS



Color: Deeper Purple (DPP)

MS1412L

- Shell Materials : Maple 6ply 5mm
- Number of Lugs : 12 lugs with aluminum tube pipes
- Weight :
MS1409 14" x 9" 12.9 lbs (5.9kg)
MS1412 14" x 12" 14.2 lbs (6.5kg)
- Strainer : Low Profile Strainer
- Snare Structure : Less stress with free floating and detachable gut frame
- Tension Rods and Washers : 6 mm strong tension rods with double washers
- Batter Side Edge Ring : Lightweight Magnesium Edge Ring for super high-pitch tuning
- Bottom Side Edge : With reinforcement ring
- Snare Guts : 11 Guts with Detachable Gut Frame
- Snare Mutes : 2 Buzz Killer Mutes included
- Hoops : Aluminum die-cast hoop
- Hardware Finish : Chrome
- Shell Finishes : 17 lacquer finishes & 1 wrap finish
- Stable Position Ring : Allows for easy replacement of the bottom head
- Legs : 2 aluminum legs prevent damage to the bottom hoop

Lacquer Finishes

Model No.	Size		
MS1409L	14"x9" MARCHING SNARE DRUM		
MS1412L	14"x12" MARCHING SNARE DRUM		



Lacquer Finish -Satin Black-

Model No.	Size		
MS1409T	14"x9" MARCHING SNARE DRUM		
MS1412T	14"x12" MARCHING SNARE DRUM		



Satin Black
SBK

Wrap Finish -Sugar White-

Model No.	Size		
MS1409K	14"x9" MARCHING SNARE DRUM		
MS1412K	14"x12" MARCHING SNARE DRUM		



Sugar White
SGW

FIELDSTAR RUDIMENT MARCHING TENOR DRUMS



Color: Satin Black (SBK)

MD680234T

- Shell Materials : Maple 6ply 5mm w/reinforcement rings on batter side
- Shell Depth :
- Spock 6"x5.5", 6"x7", 8"x7"
- Standard Toms 8"x7.5", 10"x8", 12"x9.5", 13"x11", 14x11.5" with Power Cut
- Corps Depth Toms: 10"x9.5", 12"x11", 13"x12.5", 14"x13" with Power Cut
- Lugs : Die-cast aluminum lugs
- Number of Lugs : 6" = 4, 8" = 5, 10" = 6, 12", 13", 14" = 8
- Hoops : 2.3 mm Steel Mighty Hoop
- Edge Guard : Included
- Shell Inside : Clear painted to protect inner shell
- Shell Finishes : 17 lacquer finishes & 1 wrap finish
- Hardware Finish : Chrome

Lacquer Finishes

Model No.	Size		
MT8023L	8"-10"-12"-13" SAML QUA DRUMS		
MT0234L	10"-12"-13"-14" LARGE QUA DRUMS		
MT68023L	6"-8"-10"-12"-13" SMALL QUINT DRUMS		
MT60234L	6"-10"-12"-13"-14" LARGE QUINT DRUMS		
MD60234L	6"-10"-12"-13"-14" LARGE QUINT DRUMS (CORP-DEPTH)		
MT80234L	8"-10"-12"-13"-14" LARGE QUINT DRUMS		
MT668023L	6"-6"-8"-10"-12"-13" SMALL SEXTET DRUMS		
MT660234L	6"-6"-10"-12"-13"-14" LARGE SEXTET DRUMS		
MD660234L	6"-6"-10"-12"-13"-14" LARGE SEXTET DRUMS (CORP-DEPTH)		
MT680234L	6"-8"-10"-12"-13"-14" LARGE SEXTET DRUMS		
MD680234L	6"-8"-10"-12"-13"-14" LARGE SEXTET DRUMS (CORP-DEPTH)		
MT602L	6"-10"-12" TRIO DRUMS		



Lacquer Finish -Satin Black-

Model No.	Size		
MT8023T	8"-10"-12"-13" SAML QUA DRUMS		
MT0234T	10"-12"-13"-14" LARGE QUA DRUMS		
MT68023T	6"-8"-10"-12"-13" SMALL QUINT DRUMS		
MT60234T	6"-10"-12"-13"-14" LARGE QUINT DRUMS		
MD60234T	6"-10"-12"-13"-14" LARGE QUINT DRUMS (CORP-DEPTH)		
MT80234T	8"-10"-12"-13"-14" LARGE QUINT DRUMS		
MT668023T	6"-6"-8"-10"-12"-13" SMALL SEXTET DRUMS		
MT660234T	6"-6"-10"-12"-13"-14" LARGE SEXTET DRUMS		
MD660234T	6"-6"-10"-12"-13"-14" LARGE SEXTET DRUMS (CORP-DEPTH)		
MT680234T	6"-8"-10"-12"-13"-14" LARGE SEXTET DRUMS		
MD680234T	6"-8"-10"-12"-13"-14" LARGE SEXTET DRUMS (CORP-DEPTH)		
MT602T	6"-10"-12" TRIO DRUMS		



Satin Black
SBK

Wrap Finish -Sugar White-

Model No.	Size		
MT8023K	8"-10"-12"-13" SAML QUA DRUMS		
MT0234K	10"-12"-13"-14" LARGE QUA DRUMS		
MT68023K	6"-8"-10"-12"-13" SMALL QUINT DRUMS		
MT60234K	6"-10"-12"-13"-14" LARGE QUINT DRUMS		
MD60234K	6"-10"-12"-13"-14" LARGE QUINT DRUMS (CORP-DEPTH)		
MT80234K	8"-10"-12"-13"-14" LARGE QUINT DRUMS		
MT668023K	6"-6"-8"-10"-12"-13" SMALL SEXTET DRUMS		
MT660234K	6"-6"-10"-12"-13"-14" LARGE SEXTET DRUMS		
MD660234K	6"-6"-10"-12"-13"-14" LARGE SEXTET DRUMS (CORP-DEPTH)		
MT680234K	6"-8"-10"-12"-13"-14" LARGE SEXTET DRUMS		
MD680234K	6"-8"-10"-12"-13"-14" LARGE SEXTET DRUMS (CORP-DEPTH)		
MT602K	6"-10"-12" TRIO DRUMS		



Sugar White
SGW

FIELDSTAR FREEDOM MARCHING TENOR DRUMS



Color: Molten Caramel Fade (MCF)

M668023TL

- Shell Materials : Maple 6ply 5mm w/reinforcement rings on batter side
- Shell Depth :
- Spock 6"x5.5", 6"x7", 8"x7"
- Standard Toms 8"x7.5", 10"x8", 12"x9.5", 13"x11", 14x11.5" with Power Cut
- Corps Depth Toms: 10"x9.5", 12"x11", 13"x12.5", 14"x13" with Power Cut
- Lugs : Die-cast aluminum lugs
- Number of Lugs : 6" = 4, 8" = 5, 10" = 6, 12", 13", 14" = 8
- Hoops : 2.3 mm Steel Mighty Hoop
- Edge Guard : Included
- Adjusting Tom Angle : Adjusts by loosening 4 screws with tuning key
- Legs : Three Detachable Legs
- Shell Inside : Clear painted to protect inner shell
- Shell Finishes : 17 lacquer finishes & 1 wrap finish
- Hardware Finish : Chrome

Lacquer Finishes

Model No.	Size		
M8023TL	8"-10"-12"-13" QUA DRUMS		
M68023TL	6"-8"-10"-12"-13" QUINT DRUMS		
M668023TL	6"-6"-8"-10"-12"-13" SEXTET DRUMS		
M0234TL	10"-12"-13"-14" QUA DRUMS		
M60234TL	6"-10"-12"-13"-14" QUINT DRUMS		
M60234DL	6"-10"-12"-13"-14" QUINT DRUMS (CORP-DEPTH)		
M80234TL	8"-10"-12"-13"-14" QUINT DRUMS		
M660234TL	6"-6"-10"-12"-13"-14" SEXTET DRUMS		
M660234DL	6"-6"-10"-12"-13"-14" SEXTET DRUMS (CORP-DEPTH)		
M680234TL	6"-8"-10"-12"-13"-14" SEXTET DRUMS		
M680234DL	6"-8"-10"-12"-13"-14" SEXTET DRUMS (CORP-DEPTH)		
M4TL	14"x11.5" SOLO TENOR DRUM		

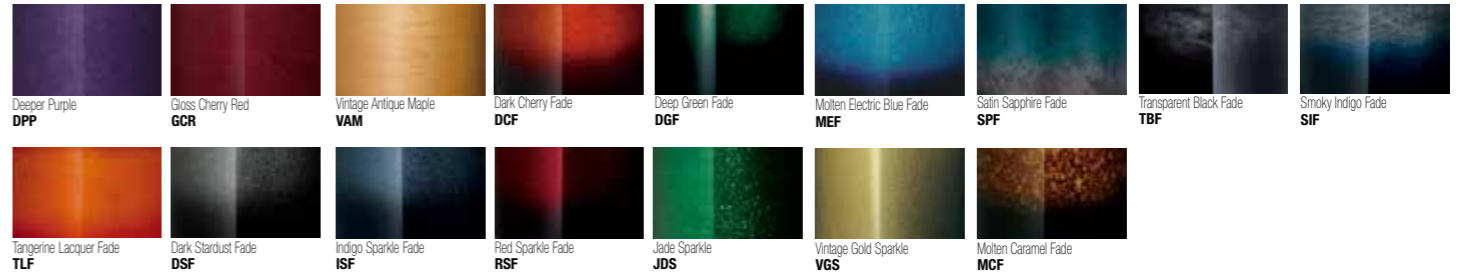

Lacquer Finish -Satin Black-

Model No.	Size		
M8023TT	8"-10"-12"-13" QUA DRUMS		
M68023TT	6"-8"-10"-12"-13" QUINT DRUMS		
M668023TT	6"-6"-8"-10"-12"-13" SEXTET DRUMS		
M0234TT	10"-12"-13"-14" QUA DRUMS		
M60234TT	6"-10"-12"-13"-14" QUINT DRUMS		
M60234DT	6"-10"-12"-13"-14" QUINT DRUMS (CORP-DEPTH)		
M80234TT	8"-10"-12"-13"-14" QUINT DRUMS		
M660234TT	6"-6"-10"-12"-13"-14" SEXTET DRUMS		
M660234DT	6"-6"-10"-12"-13"-14" SEXTET DRUMS (CORP-DEPTH)		
M680234TT	6"-8"-10"-12"-13"-14" SEXTET DRUMS		
M680234DT	6"-8"-10"-12"-13"-14" SEXTET DRUMS (CORP-DEPTH)		
M4TT	14"x11.5" SOLO TENOR DRUM		



Satin Black
SBK

Wrap Finish -Sugar White-

Model No.	Size		
M8023TK	8"-10"-12"-13" QUA DRUMS		
M68023TK	6"-8"-10"-12"-13" QUINT DRUMS		
M668023TK	6"-6"-8"-10"-12"-13" SEXTET DRUMS		
M0234TK	10"-12"-13"-14" QUA DRUMS		
M60234TK	6"-10"-12"-13"-14" QUINT DRUMS		
M60234DK	6"-10"-12"-13"-14" QUINT DRUMS (CORP-DEPTH)		
M80234TK	8"-10"-12"-13"-14" QUINT DRUMS		
M660234TK	6"-6"-10"-12"-13"-14" SEXTET DRUMS		
M660234DK	6"-6"-10"-12"-13"-14" SEXTET DRUMS (CORP-DEPTH)		
M680234TK	6"-8"-10"-12"-13"-14" SEXTET DRUMS		
M680234DK	6"-8"-10"-12"-13"-14" SEXTET DRUMS (CORP-DEPTH)		
M4TK	14"x11.5" SOLO TENOR DRUM		



Sugar White
SGW

FIELDSTAR MARCHING BASS DRUMS



Color: Satin Black (SBK)

MB2214T

-Shell Materials : Maple 8ply 6mm
 -Weight :
 MB1414 14"x14" 14.5lbs (6.6kg)
 MB1614 16"x14" 15.7lbs (7.1kg)
 MB1814 18"x14" 16.5lbs (7.5kg)
 MB2014 20"x14" 19.0lbs (8.6kg)
 MB2214 22"x14" 20.1lbs (9.1kg)
 MB2414 24"x14" 21.3lbs (9.7kg)
 MB2614 26"x14" 22.5lbs (10.2kg)
 MB2814 28"x14" 23.7lbs (10.8kg)
 MB3014 30"x14" 24.9lbs (11.3kg)

-Attachment for carrier : Noiseless carrier attachment
 -Lugs : Die-cast aluminum high-tension lugs
 -Number of lugs : 14" - 18" = 8 lugs, 20" - 28" = 10 lugs, 30" = 12 lugs
 -Claw Hooks : Designed with superior strength for high-pitch tuning
 -Hoops : High-gloss black lacquer finish
 -Shell Finishes : 17 lacquer finishes & 1 wrap finish
 -Hardware Finish : Chrome

Lacquer Finishes

Model No.	Size		
MB1414L	14"x14" MARCHING BASS DRUM		
MB1614L	16"x14" MARCHING BASS DRUM		
MB1814L	18"x14" MARCHING BASS DRUM		
MB2014L	20"x14" MARCHING BASS DRUM		
MB2214L	22"x14" MARCHING BASS DRUM		
MB2414L	24"x14" MARCHING BASS DRUM		
MB2614L	26"x14" MARCHING BASS DRUM		
MB2814L	28"x14" MARCHING BASS DRUM		
MB3014L	30"x14" MARCHING BASS DRUM w/o drum heads		



Lacquer Finishes -Satin Black-

Model No.	Size		
MB1414T	14"x14" MARCHING BASS DRUM		
MB1614T	16"x14" MARCHING BASS DRUM		
MB1814T	18"x14" MARCHING BASS DRUM		
MB2014T	20"x14" MARCHING BASS DRUM		
MB2214T	22"x14" MARCHING BASS DRUM		
MB2414T	24"x14" MARCHING BASS DRUM		
MB2614T	26"x14" MARCHING BASS DRUM		
MB2814T	28"x14" MARCHING BASS DRUM		
MB3014T	30"x14" MARCHING BASS DRUM w/o drum heads		



Wrap Finish -Sugar White-

Model No.	Size		
MB1414K	14"x14" MARCHING BASS DRUM		
MB1614K	16"x14" MARCHING BASS DRUM		
MB1814K	18"x14" MARCHING BASS DRUM		
MB2014K	20"x14" MARCHING BASS DRUM		
MB2214K	22"x14" MARCHING BASS DRUM		
MB2414K	24"x14" MARCHING BASS DRUM		
MB2614K	26"x14" MARCHING BASS DRUM		
MB2814K	28"x14" MARCHING BASS DRUM		
MB3014K	30"x14" MARCHING BASS DRUM w/o drum heads		



STARLIGHT MARCHING SNARE DRUMS



Color: Satin Black (SBK)

R1412SL

-Shell : Birch 8mm 8ply
 -Hoop : 2.3mm Steel Mighty Hoop
 -Number of Lugs : 12 lugs with aluminum tube pipes
 -Strainer : Quick touch snare strainer
 -Batter Side Edge Ring : Aluminum die-cast edge ring for super high-pitch tuning
 -Snare Wires : 20-strand Carbon Steel Snappy Snares

Lacquer Finish -Satin Black-

Model No.	Size		
R1412SL	14"x12" MARCHING SNARE DRUM		



Wrap Finish -Sugar White-

Model No.	Size		
R1412SK	14"x12" MARCHING SNARE DRUM		



STARLIGHT MARCHING TENOR DRUMS



Color: Sugar White (SGW)

R8023TK

-Shell : Birch 8mm 8ply
 -Hoop : 1.6mm Steel Triple Flanged
 -Adjusting Tom Angle (for Quad)
 -Edge Guard included

Lacquer Finish -Satin Black-

Model No.	Size		
R8023TL	8"-10"-12"-13" QUAD DRUMS		
R802TL	8"-10"-12" TRIO DRUMS		
R4TL	14"x11.5" SOLO TENOR DRUM		
R0655TLP	6"x5.5" TOM FOR TENOR DRUM		

Wrap Finish -Sugar White-

Model No.	Size		
R8023TK	8"-10"-12"-13" QUAD DRUMS		
R802TK	8"-10"-12" TRIO DRUMS		
R4TK	14"x11.5" SOLO TENOR DRUM		
R0655TKP	6"x5.5" TOM FOR TENOR DRUM		

STARLIGHT MARCHING BASS DRUMS



Color: Sugar White (SGW)

R2214BK

-Shell : Birch 7mm 7ply
 -Attachment for carrier : Noiseless carrier attachment
 -Lug : Die-cast aluminum high-tension lugs
 -Number of lugs : 16" - 18" = 8 lugs, 20" - 28" = 10 lugs
 -Claw Hook : Designed with superior strength for high-pitch tuning
 -Hoop : High-gloss black lacquer finish

Lacquer Finish -Satin Black-

Model No.	Size		
R1614BL	16"x14" MARCHING BASS DRUM		
R1814BL	18"x14" MARCHING BASS DRUM		
R2014BL	20"x14" MARCHING BASS DRUM		
R2214BL	22"x14" MARCHING BASS DRUM		
R2414BL	24"x14" MARCHING BASS DRUM		
R2614BL	26"x14" MARCHING BASS DRUM		
R2814BL	28"x14" MARCHING BASS DRUM		

Wrap Finish -Sugar White-

Model No.	Size		
R1614BK	16"x14" MARCHING BASS DRUM		
R1814BK	18"x14" MARCHING BASS DRUM		
R2014BK	20"x14" MARCHING BASS DRUM		
R2214BK	22"x14" MARCHING BASS DRUM		
R2414BK	24"x14" MARCHING BASS DRUM		
R2614BK	26"x14" MARCHING BASS DRUM		
R2814BK	28"x14" MARCHING BASS DRUM		



FIELDSTAR CARRIER FOR SNARE DRUM



CFSSDT

- Sliding Height Adjustment
- Safety Lock Mount
- Positioning Bar
- Belly Pad
- Shoulder Pipe Adjustment
- Backrest Adjustment
- Movable Pad

FIELDSTAR CARRIER FOR TENOR DRUM



CFSTNT

- Sliding Height Adjustment
- Safety Lock Mount
- Positioning Bar
- Drum Lift Bumper
- Belly Pad
- Shoulder Pipe Adjustment
- Backrest Adjustment
- Movable Pad

SILVER ARMOR CARRIER "J-BAR TYPE" FOR TENOR DRUM



CSATNM

- Sliding Height Adjustment
- Drum Lift Bumper
- Belly Pad
- Shoulder Pipe Adjustment
- Backrest Adjustment
- Movable Pad
- Suitable for general J-bar type carrier for Tenor drums that have 14mm diameter rod
- Not fit to Tama Marching Tenor Drums

SILVER ARMOR CARRIER "HOOK TYPE" FOR BASS DRUM



CSABDM

- Sliding Height Adjustment
- Two-way Support Bar
- Belly Pad
- Shoulder Pipe Adjustment
- Backrest Adjustment
- Movable Pad
- Suitable for general locking type of carrier for bass drum with eyebolt. The distance between eyebolt hook can be adjustable within the range from 165mm to 250mm.
- Not fit to Tama Marching Bass Drums

FIELDSTAR CARRIER FOR BASS DRUM



CFSBDT

- Sliding Height Adjustment
- Safety Lock Mount
- Two-way Support Bar
- Belly Pad
- Shoulder Pipe Adjustment
- Backrest Adjustment
- Movable Pad

FIELDSTAR CARRIER "J-BAR TYPE" FOR SNARE DRUM



CFSSDM

- Sliding Height Adjustment
- Belly Pad
- Shoulder Pipe Adjustment
- Backrest Adjustment
- Movable Pad
- Suitable for general J-bar type carrier for Snare drums that have 14mm diameter rod
- Not fit to Tama Marching Snare Drums

STARLIGHT CARRIER FOR SNARE DRUM



CRSDT

- Sliding Height Adjustment
- Safety Lock Mount

STARLIGHT CARRIER FOR TENOR DRUM



CRTNT

- Sliding Height Adjustment
- Safety Lock Mount

FIELDSTAR CARRIER "J-BAR TYPE" FOR TENOR DRUM



CFSTNM

- Sliding Height Adjustment
- Drum Lift Bumper
- Belly Pad
- Shoulder Pipe Adjustment
- Backrest Adjustment
- Movable Pad
- Suitable for general J-bar type carrier for Tenor drums that have 14mm diameter rod
- Not fit to Tama Marching Tenor Drums

FIELDSTAR CARRIER "HOOK TYPE" FOR BASS DRUM



CFSBDM

- Sliding Height Adjustment
- Two-way Support Bar
- Belly Pad
- Shoulder Pipe Adjustment
- Backrest Adjustment
- Movable Pad
- Suitable for general locking type of carrier for bass drum with eyebolt. The distance between eyebolt hook can be adjustable within the range from 165mm to 250mm.
- Not fit to Tama Marching Bass Drums

STARLIGHT CARRIER FOR BASS DRUM



CRBDT

- Sliding Height Adjustment
- Safety Lock Mount
- Two-way Support Bar

SAFETY LOCK MARCHING STAND FOR SNARE DRUM



HMSD79WSN

- Snare Anti-Shake Bumper
- Upside Down Setting
- Safety Lock Mount
- Center of Gravity Position
- Adjustable 2 Front Legs
- Glide-Tite Grip Joint
- Double Braced Legs

SILVER ARMOR CARRIER FOR SNARE DRUM



CSASDT

- Sliding Height Adjustment
- Safety Lock Mount
- Positioning Bar
- Belly Pad
- Shoulder Pipe Adjustment
- Backrest Adjustment
- Movable Pad

SILVER ARMOR CARRIER FOR TENOR DRUM



CSATNT

- Sliding Height Adjustment
- Safety Lock Mount
- Positioning Bar
- Drum Lift Bumper
- Belly Pad
- Shoulder Pipe Adjustment
- Backrest Adjustment
- Movable Pad

SAFETY LOCK MARCHING STAND FOR TENOR DRUM



HMTN79WSZ

- Fold and Positioning Bar
- Tenor Anti-Chace Support Bar
- Safety Lock Mount
- Center of Gravity Position
- Adjustable 2 Front Legs
- Glide-Tite Grip Joint
- Double Braced Legs

UNIVERSAL MARCHING STAND FOR BASS DRUM



HMBD79WSM

- Center of Gravity Position
- Adjustable 2 Front Legs
- Glide-Tite Grip Joint
- Double Braced Legs

SILVER ARMOR CARRIER FOR BASS DRUM



CSABDT

- Sliding Height Adjustment
- Safety Lock Mount
- Two-way Support Bar
- Belly Pad
- Shoulder Pipe Adjustment
- Backrest Adjustment
- Movable Pad

SILVER ARMOR CARRIER "J-BAR TYPE" FOR SNARE DRUM



CSASDM

- Sliding Height Adjustment
- Belly Pad
- Shoulder Pipe Adjustment
- Backrest Adjustment
- Movable Pad
- Suitable for general J-bar type carrier for Snare drums that have 14mm diameter rod
- Not fit to Tama Marching Snare Drums

SAFETY LOCK MARCHING NON STADIUM STAND FOR SNARE DRUM



HMSD79WN

- Snare Anti-Shake Bumper
- Upside Down Setting
- Safety Lock Mount
- Center of Gravity Position
- Glide-Tite Grip Joint
- Double Braced Legs

SAFETY LOCK MARCHING NON STADIUM STAND FOR TENOR DRUM



HMTN79WZ

- Fold and Positioning Bar
- Tenor Anti-Shake Support Bar
- Safety Lock Mount
- Center of Gravity Position
- Glide-Tite Grip Joint
- Double Braced Legs

UNIVERSAL NON STADIUM MARCHING STAND FOR BASS DRUM



HMBD79WM

-Center of Gravity Position
-Glide-Tite Grip Joint
-Double Braced Legs

MARCHING DRUM PROTECT COVERS FOR SNARE DRUM



CVS1412N

CVS1412N (for 14"x12" Snare Drum)
CVS1409N (for 14"x9" Snare Drum)

TAMA LOGO STICKER -White-



TLS100WH

TLS120WH 60mm x 280mm
TLS100WH 50mm x 230mm
TLS80WH 40mm x 190mm
TLS70WH 35mm x 150mm

TAMA LOGO STICKER -Black-



TLS100BK

TLS120BK 60mm x 280mm
TLS100BK 50mm x 230mm
TLS80BK 40mm x 190mm
TLS70BK 35mm x 150mm

MARCHING DRUM PROTECT COVERS FOR TENOR DRUM



CVTL

CVTL (Large Size 10/12/13/14)
CVTS (Small Size 8/10/12/13)

MARCHING DRUM PROTECT COVERS FOR BASS DRUM



CVB2224N

CVB1416N (for 14"x16" Bass Drum)
CVB1820N (for 18"x20" Bass Drum)
CVB2224N (for 22"x24" Bass Drum)
CVB2628N (for 26"x28" Bass Drum)
CVB30N (for 30" Bass Drum)

GUT FRAME ASSEMBLY



MGF14BR

TAMA Brown Guts are produce a crisp and warm sound. The gut frame can be instantly changed to produce the sound of your choice.

SNARE MUTE



MSMT

HOOP GRIP & Z-ROD FOR HI-HAT CYMBALS



MC8ZHH

Hoop Grip (MCB) & Z-Rod for Hi-Hat Cymbals (ZHH) bundle package

Z-ROD FOR HI-HAT CYMBALS



ZHH

Z-rod for mounting Hi-Hat cymbals

Details:
- Screw Type Hi-Hat Clutch

MULTI LOCK CLAMP



MLC79

BASS DRUM MUFFLE RINGS



MBSP2

(2pcs/set)

SNARE PROJECTER



TPS14W

For 14" Snare Drums

TPS14W (White)
TPS14B2 (Black)
TPS14C (Clear)

BASS DRUM HOOP GUARD



MBRG14

TAMA Hoop Guards can be securely locked to bass drum hoops using the friction of rubber cushions. The rubber cushions protect the hoops from scratches and the Hoop Guards protect the hoops from rim shots.

TURNING KEY



THDK20

Hi-Tension Tuning Key

BACK SUPPORT BELT FOR CARRIER



CSABSB

The Back Support Belt gives extra support while reducing back stress. Designed to be used with TAMA Fieldstar and Silver Armor Carriers, (sold separately), it can be easily adjusted for different body types and is removeable.

BASS DRUM HOOP GUARD



MBHG100

TAMA Hoop Guards can be securely locked to bass drum hoops. The rubber cushions protect the hoops from scratches and the Hoop Guards protect the hoops from rim shots.

Bass Drum Mallet Holder



MBMH100

This mallet holder holds the 2 pairs of mallets by secure and easy retaining system. Also attaching this unit to bass drum without any screws tightening

CONCERT PERCUSSION

We offer Concert Percussion lineup with snare drums, toms, and hardware. STARPHONIC Concert Snare Drums are built to the absolute pinnacle of quality and design, and they carry a sound that's to be expected from any instrument bearing the name TAMA.

BILL PLATT SIGNATURE



BP146 MADE IN JAPAN
 Shell: 3mm Bell Brass w/3 Air Vents
 Size: 14"x6"
 Lug: Freedom Lug
 Hoop: Grooved Straight Hoop (10 tension)
 Strainer/Butt: MLS50AD/MLS50BD w/ Multi Snare Frame
 Snare Wire: Three Different Snare Wire
 Nickel Wound Round Guitar String (MSGW14M, 6 strands)
 Black Nylon Coated Stainless Steel Wire (MSGNCS14M, 6 strands)
 Uncoated Stainless Steel Straight Wire (MSGUCS14M, 6 strands)

STARPHONIC MAPLE BRAVURA CONCERT



Color: Gloss Mocha Brown -GMC

CMP146MF MADE IN JAPAN
 Shell: 6mm, 7ply 100% Maple
 Size: 14"x6"
 Lug: Freedom Lug
 Hoop: Grooved Straight Hoop (10 hole)
 Strainer/Butt: MLS50AD/MLS50BD w/Multi Snare Frame
 Snare Wire: Three Different Snare Wire
 Nickel Wound Round Guitar String (6 strands)
 Black Nylon Coated Stainless Steel Wire (6 strands)
 Hi-Carbon Coil Snare Wire (6 strands)
 Color: Piano Black (PBK), Gloss Mocha Brown (GMC)

STARPHONIC MAPLE CONCERT



Color: Piano Black -PBK

CMP146 MADE IN JAPAN
 Shell: 6mm, 7ply 100% Maple
 Size: 14"x6"
 Lug: Freedom Lug
 Hoop: Grooved Straight Hoop (10 hole)
 Strainer/Butt: MLS50AC/MLS50BC w/Fine Adjuster
 Snare Wire: Hybrid Snare Wire
 Nickel Wound Round Guitar String (6 strands in the center)
 Black Nylon Coated Stainless Steel Wire (3 strands each outside)
 Color: Piano Black (PBK), Gloss Cherry Red (GCR)

STARPHONIC BUBINGA BRAVURA CONCERT



Color: Gloss Natural Cordia -GNC

CBC146MF MADE IN JAPAN
 Shell: 7mm, 7ply 100% Bubinga + 1 outer ply Cordia
 Size: 14" x 6"
 Lug: Freedom Lug
 Hoop: Grooved Straight Hoop (10 hole)
 Strainer/Butt: MLS50AD/MLS50BD w/ Multi Snare Frame
 Snare Wire: Three Different Snare Wire
 Nickel Wound Round Guitar String (6 strands)
 Black Nylon Coated Stainless Steel Wire (6 strands)
 Stainless Steel Wire (6 strands)
 Color: Gloss Natural Cordia (GNC)

STARPHONIC ALUMINUM BRAVURA CONCERT



CAL146MF MADE IN JAPAN
 Shell: 3mm Aluminum
 Size: 14"x6"
 Lug: Freedom Lug
 Hoop: Grooved Straight Hoop
 Strainer/Butt: MLS50AD / MLS50BD w/Multi Snare Frame
 Snare Wire: Three Different Snare Wire
 Nickel Wound Round Guitar String (6 strands)
 Black Nylon Coated Stainless Steel Wire (6 strands)
 Hi-Carbon Coil Snare Wire (6 strands)

STARPHONIC ALUMINUM CONCERT



CAL146 MADE IN JAPAN
 Shell: 3mm Aluminum
 Size: 14"x6"
 Lug: Freedom Lug
 Hoop: Grooved Straight Hoop
 Strainer/Butt: MLS50AC / MLS50BC w/Fine Adjuster
 Snare Wire: Hybrid Snare Wire
 Nickel Wound Round Guitar String (6 strands in the center)
 Black Nylon Coated Stainless Steel Wire (3 strands each outside)

STARPHONIC WALNUT BRAVURA FIELD DRUM



Color: Gloss Black Walnut (GBW)

CWN1414MF MADE IN JAPAN
 Shell: 6mm, 7ply 100% Walnut
 Size: 14"x14"
 Lug: Freedom Lug
 Hoop: Grooved Straight Hoop (10 hole)
 Strainer/Butt: MLS50AD/MLS50BD w/Multi Snare Frame
 Snare Wire: Three Different Snare Wire
 Nickel Wound Round Guitar String (6 strands)
 Black Nylon Coated Stainless Steel Wire (6 strands)
 Hi-Carbon Coil Snare Wire (6 strands)
 Color: Gloss Black Walnut (GBW)

CONCERT MAPLE



Color: Piano Black (PBK)

CLMP1465
 Shell: 6mm, 7ply 100% Maple
 Size: 14"x6.5"
 Lug: MTL60
 Hoop: Steel Mighty Hoop (10 hole)
 Strainer/Butt: MLS50AC/MLS50BC w/Fine Adjuster
 Snare Wire: Hybrid Snare Wire
 Nickel Wound Round Guitar String (6 strands in the center)
 Black Nylon Coated Stainless Steel Wire (3 strands each outside)
 Color: Piano Black (PBK), Vintage Antique Maple (VAM)

CONCERT MAPLE



Color: Vintage Antique Maple (VAM)

CLMP145
 Shell: 6mm, 7ply 100% Maple
 Size: 14"x5"
 Lug: MTL50
 Hoop: Steel Mighty Hoop (10 hole)
 Strainer/Butt: MLS50AC/MLS50BC w/Fine Adjuster
 Snare Wire: Hybrid Snare Wire
 Nickel Wound Round Guitar String (6 strands in the center)
 Black Nylon Coated Stainless Steel Wire (3 strands each outside)
 Color: Piano Black (PBK), Vintage Antique Maple (VAM)

CONCERT TOM SET -SINGLE HEAD-



Color: Vintage Antique Maple -VAM-

CSLT4H
 High-Pitched Concert Tom Set
 6"x6" Tom Tom, 8"x7" Tom Tom, 10"x8" Tom Tom, 12"x9" Tom Tom
 - 100% Maple Shell
 - Direct-Flexi Mount
 [Available Finishes]
 --Vintage Antique Maple (VAM)
 --Transparent Black Fade (TBF)

CONCERT TOM SET -SINGLE HEAD-



Color: Vintage Antique Maple -VAM-

CSLT4M
 Mid-Pitched Concert Tom Set
 10"x8" Tom Tom, 12"x9" Tom Tom, 13"x11" Tom Tom, 14"x12" Tom Tom
 - 100% Maple Shell
 - Direct-Flexi Mount
 [Available Finishes]
 --Vintage Antique Maple (VAM)
 --Transparent Black Fade (TBF)

CONCERT TOM SET -SINGLE HEAD-



Color: Vintage Antique Maple -VAM-

CSLT4L
 Low-Pitched Concert Tom Set
 12"x10" Tom Tom, 13"x11" Tom Tom, 14"x12" Tom Tom, 16"x13" Tom Tom
 - 100% Maple Shell
 - Direct-Flexi Mount
 [Available Finishes]
 --Vintage Antique Maple (VAM)
 --Transparent Black Fade (TBF)

CONCERT TOM -SINGLE HEAD-



Color: Vintage Antique Maple -VAM-

CSLT6A
 6"x6" Tom Tom
 [Available Finishes]
 --Vintage Antique Maple (VAM)
 --Transparent Black Fade (TBF)

CONCERT TOM -SINGLE HEAD-



Color: Vintage Antique Maple -VAM-

CSLT8A
 8"x7" Tom Tom
 [Available Finishes]
 --Vintage Antique Maple (VAM)
 --Transparent Black Fade (TBF)

CONCERT TOM -SINGLE HEAD-



Color: Vintage Antique Maple -VAM-

CSLT10A
 10"x8" Tom Tom
 [Available Finishes]
 --Vintage Antique Maple (VAM)
 --Transparent Black Fade (TBF)

CONCERT TOM -SINGLE HEAD-



Color: Vintage Antique Maple -VAM-

CSLT12A
 12"x9" Tom Tom
 [Available Finishes]
 --Vintage Antique Maple (VAM)
 --Transparent Black Fade (TBF)

CONCERT TOM -SINGLE HEAD-



Color: Vintage Antique Maple -VAM-

CSLT12D
 12"x10" Tom Tom
 [Available Finishes]
 --Vintage Antique Maple (VAM)
 --Transparent Black Fade (TBF)

CONCERT TOM -SINGLE HEAD-



Color: Vintage Antique Maple -VAM-

CSLT13D
 13"x11" Tom Tom
 [Available Finishes]
 --Vintage Antique Maple (VAM)
 --Transparent Black Fade (TBF)

CONCERT TOM -SINGLE HEAD-



Color: Vintage Antique Maple -VAM-

CSLT14D
 14"x12" Tom Tom
 [Available Finishes]
 --Vintage Antique Maple (VAM)
 --Transparent Black Fade (TBF)

CONCERT TOM -SINGLE HEAD-



Color: Vintage Antique Maple -VAM-

CSLT16D
 16"x14" Tom Tom
 [Available Finishes]
 --Vintage Antique Maple (VAM)
 --Transparent Black Fade (TBF)

CONCERT TOM SET -DOUBLE HEAD-



Color: Transparent Black Burst -TPB-

CCLT4H
 High-Pitched Concert Tom Set
 6"x6" Tom Tom, 8"x7" Tom Tom, 10"x8" Tom Tom, 12"x9" Tom Tom
 - 100% Maple Shell
 - Direct-Flexi Mount
 [Available Finishes]
 --Vintage Antique Maple (VAM)
 --Transparent Black Burst (TPB)

CONCERT TOM SET -DOUBLE HEAD-



Color: Transparent Black Burst -TPB-

CCLT4M
 Mid-Pitched Concert Tom Set
 10"x8" Tom Tom, 12"x9" Tom Tom, 13"x11" Tom Tom, 14"x12" Tom Tom
 - 100% Maple Shell
 - Direct-Flexi Mount
 [Available Finishes]
 --Vintage Antique Maple (VAM)
 --Transparent Black Burst (TPB)

CONCERT TOM SET -DOUBLE HEAD-



Color: Transparent Black Burst -TPB-

CCLT4L

Low-Pitched Concert Tom Set
12"x10" Tom Tom, 13"x11" Tom Tom, 14"x12"
Tom Tom, 16"x14" Tom Tom

- 100% Maple Shell
- Direct-Flexi Mount

[Available Finishes]
-Vintage Antique Maple (VAM)
-Transparent Black Burst (TPB)

CONCERT TOM -DOUBLE HEAD-



Color: Transparent Black Burst -TPB-

CCLT6A

6"x6" Tom Tom

[Available Finishes]
-Vintage Antique Maple (VAM)
-Transparent Black Burst (TPB)

CONCERT TOM -DOUBLE HEAD-



Color: Transparent Black Burst -TPB-

CCLT8A

8"x7" Tom Tom

[Available Finishes]
-Vintage Antique Maple (VAM)
-Transparent Black Burst (TPB)

CONCERT TOM -DOUBLE HEAD-



Color: Transparent Black Burst -TPB-

CCLT10A

10"x8" Tom Tom

[Available Finishes]
-Vintage Antique Maple (VAM)
-Transparent Black Burst (TPB)

CONCERT TOM -DOUBLE HEAD-



Color: Transparent Black Burst -TPB-

CCLT12A

12"x9" Tom Tom

[Available Finishes]
-Vintage Antique Maple (VAM)
-Transparent Black Burst (TPB)

CONCERT TOM -DOUBLE HEAD-



Color: Transparent Black Burst -TPB-

CCLT12D

12"x10" Tom Tom

[Available Finishes]
-Vintage Antique Maple (VAM)
-Transparent Black Burst (TPB)

CONCERT TOM -DOUBLE HEAD-



Color: Transparent Black Burst -TPB-

CCLT13D

13"x11" Tom Tom

[Available Finishes]
-Vintage Antique Maple (VAM)
-Transparent Black Burst (TPB)

CONCERT TOM -DOUBLE HEAD-



Color: Transparent Black Burst -TPB-

CCLT14D

14"x12" Tom Tom

[Available Finishes]
-Vintage Antique Maple (VAM)
-Transparent Black Burst (TPB)

CONCERT TOM -DOUBLE HEAD-



Color: Transparent Black Burst -TPB-

CCLT16D

16"x14" Tom Tom

[Available Finishes]
-Vintage Antique Maple (VAM)
-Transparent Black Burst (TPB)

CONCERT SNARE STAND - ROADPRO



HS80HWN

For 12" to 15" Diameter Snare Drums

- Quick-Set Tilter
- Swiveling Basket
- Glide-Tite Grip Joint
- Double Braced Legs
- Weight: 3.7kg (8.2lbs)
- Height Adjustment Range: 640mm - 925mm
(25 3/16" - 36 3/8")

CONCERT SNARE STAND - THE CLASSIC STAND



HS50HF

- Flat Base Leg Design
- Classic Style Basket
- Double Braced Arms
- Gearless Tilter
- Weight: 1.9kg (4.2lbs)
- Height Adjustment Range: 630mm-860mm (24
13/16" - 33 7/8")

DOUBLE TOM STAND



HTW839W

- 28.6mm Diameter Base Section Tubing
- Omni-Ball Tom Angle Adjustment
- Still System
- Glide-Tite Grip Joint
- Double Braced Legs
- Weight: 5.0kg (11lbs)
- Height Adjustment Range: 790-1,270mm (31
1/8" - 50")

PERCUSSION TABLE



HTB86LS

- 25.4mm Diameter Base Section Tubing
- Table Size: 600mm width x 450mm length
- Glide-Tite Grip Joint
- Single Braced Legs
- Weight: 5.5kg (12.1lbs)

POWERPAD® BAG -Concert Snare Drum-



PBSC146

- For Tama Concert Snare Drum
- Five-Layered Semi-Hard Resin Structure
- 30mm Groove to Securely House Multi Snare
Frame